



SCADA SYSTEMS

ONE DAY SEMINAR

Contact Arthur Zatarain, PE
via www.artzat.com
For information on this document





Founded 1970

Engineering and Fabrication

Pneumatic, Electrical,
and Electronic Controls

Technical Field Services

MMS Testing Services



INSTALLATION HISTORY

First Installation Sept 1988

Most systems completely installed by TEST.

Using phone, voice radio, data radio, microwave, and Cellular Phone

Manned, Unmanned, and office locations.



SCADA SYSTEM DEVELOPMENT

All software done in-house

Constant enhancements based on actual installations.

Hardware Improvements to reduce power and improve performance in the field.

Maintain compability with existing TEST systems.



TEST INC.

SCADA
SYSTEMS

INTRODUCTORY
COURSE



U. P. S.

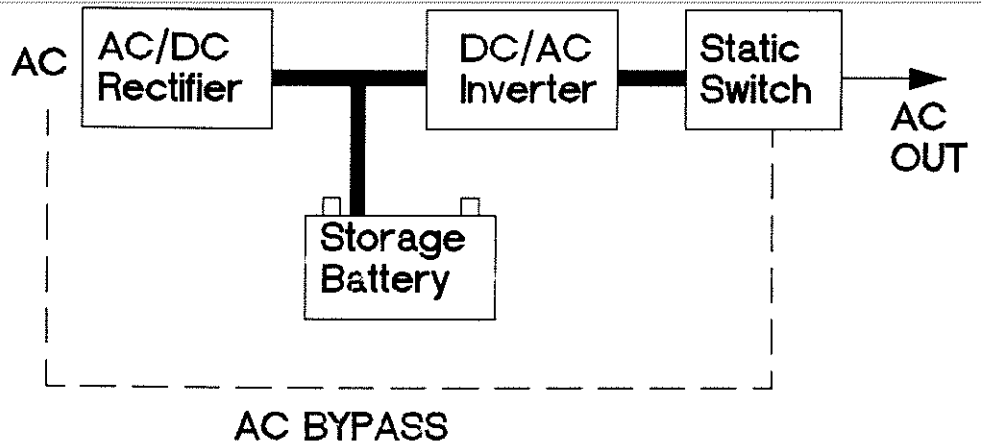

Provides Backup AC
Continuous or Standby
Battery sets Time



MODEM CIRCUIT

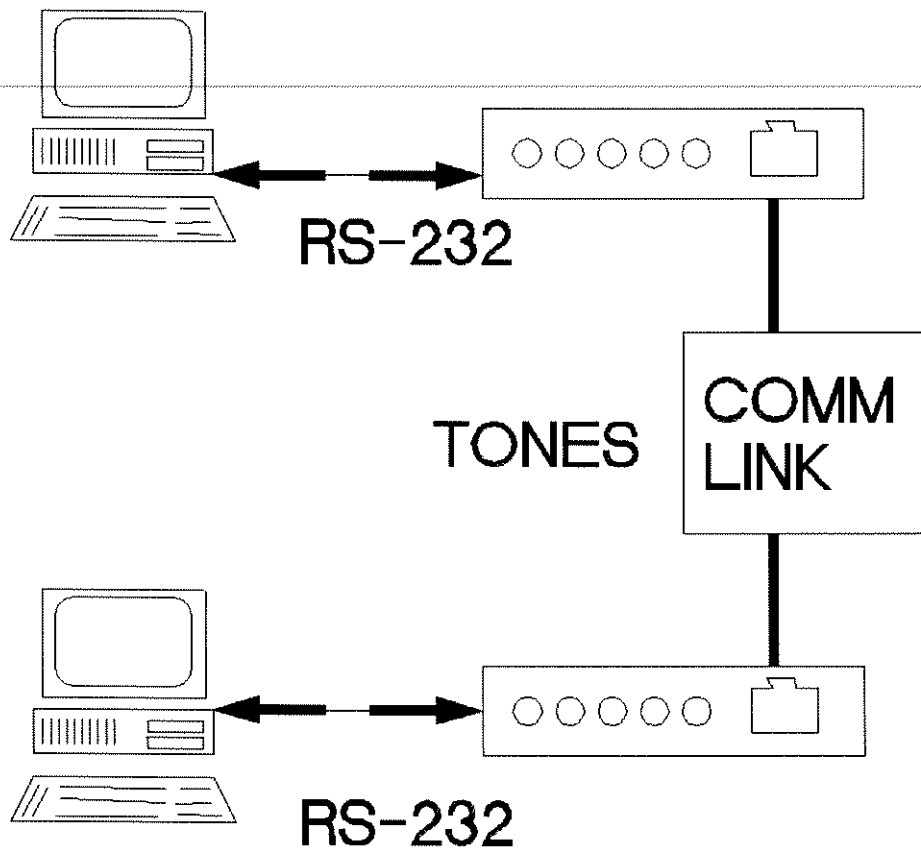

SCADA TERMINOLOGY

SCADA	Supervisory Control and Data Acquisition
RTU	Remote Terminal Unit Remote Telemetry Unit
HOST	Central Computer that Receives RTU Information
CHANNEL	One Data Point or Value Within the System
LINK	A Communication Path Between Two Units



DATARAN HISTORY

Founded 1980 as Electrical Engineering Firm.

Specalized in industrial power and control designs

Extensive computer experience including programming and hardware design.

Fabricated Computer Systems.

Purchased by TEST in Dec. 1987



DESIGN FEATURES

Flexible Hardware and Software

Based on Actual Installations

Uses Standard Hardware

DOS Based Software

Features for Offshore and
Remote Locations



SYSTEM MODES

Stand Alone System Monitor

Remote Terminal to Host

Manned Terminal to Host

Host to Host Links

Monitor and Control Capability



HARDWARE FEATURES

Based on Standard Components

Not tied to any Vendor

Allows future enhancements

Tailored to each location

Low power options

High Speed Options



RTU FUNCTIONS

Remote Terminal Unit (RTU)

Provide Remote Information
back to Office (HOST) location

Provide Local Process Info

Limited Control at Remote

Generate Production Info

Relay info Host-to-Host



SOFTWARE FEATURES

Multi-Tasking Program

Operate under DOS system

Provide SCADA specific functions

Allow configuration in the field by the user

Same program at RTU and HOST

Allow customization for each user in the field

Allow best use of Hardware



RTU TASKS

Provide command processing for RTU related functions

Interfaces to Humans as well as other RTU systems

Receives input from People, files other tasks, and comm ports

May operate without console

Same code for all instances

Local CRT has special tricks



POINT SCANNER

Looks for changes in alarm status for all channels

Provides calculation for AGA meter channels

Adjusted for RTU or HOST

Overhead based on number of channels needing service



I/O H.W. DRIVER

Reads physical I/O points

Must be configured for each specific location

Slightly different for each type of I/O hardware

More than one driver can be managed by single task



ONE SECOND TASK

Scheduled once per second

Processes timers, totals, and other time related data

Catches up if running late

Must be on all systems



TYPICAL SETUP

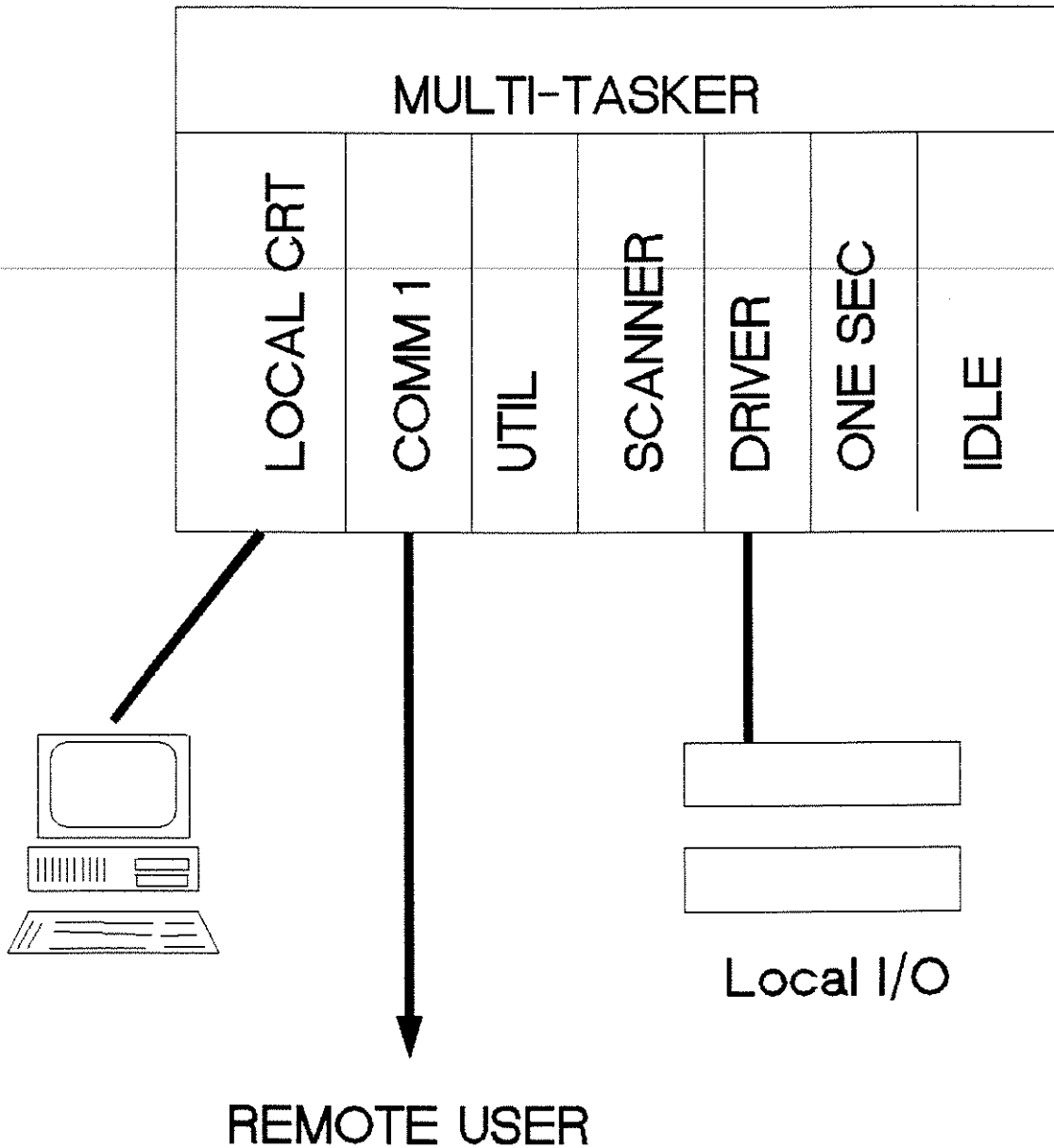

MULTI-TASKER

Allows many simultaneous program activities

Local CRT, remote interfaces, and other background tasks

Configured for each RTU

Allows optimum setup for each hardware combination

Bends many DOS rules



SOFTWARE FEATURES

Multi-Tasking Program

Operate under DOS system

Provide SCADA specific functions

Allow configuration in the field by the user

Same program at RTU and HOST

Allow customization for each user in the field

Allow best use of Hardware



SOFTWARE FEATURES

Multi-Tasking Program

Operate under DOS system

Provide SCADA specific functions

Allow configuration in the field by the user

Same program at RTU and HOST

Allow customization for each user in the field

Allow best use of Hardware



PROGRAM MODULES

RTUMON.EXE

Main DOS program Module

Controls all RTU processes

Multi-Tasks under DOS

RTUMON.OVR

Contains startup procedures and functions used by local CRT

Must be matched to EXE file

May be on separate fast drive

CONFIG FILES

Tells program about each individual location setup for RTU and location related information



MULTI-TASKER

Allows many simultaneous program activities

Local CRT, remote interfaces, and other background tasks

Configured for each RTU

Allows optimum setup for each hardware combination

Bends many DOS rules



RTU TASKS

Provide command processing for RTU related functions

Interfaces to Humans as well as other RTU systems

Receives input from People, files other tasks, and comm ports

May operate without console

Same code for all instances

Local CRT has special tricks



POINT SCANNER

Looks for changes in alarm status for all channels

Provides calculation for AGA meter channels

Adjusted for RTU or HOST

Overhead based on number of channels needing service



I/O H.W. DRIVER

Reads physical I/O points

Must be configured for each specific location

Slightly different for each type of I/O hardware

More than one driver can be managed by single task



ONE SECOND TASK

Scheduled once per second

Processes timers, totals, and other time related data

Catches up if running late

Must be on all systems



IDLE TASK

Required by Multi-Tasker

Fills any idle CPU time

Automatically allocated by system at startup

Always last assigned task

Cannot be stopped



RTU COMMANDS

Processed by RTU, Utility, and Calculator Tasks only

Consist of Command and some number of keywords or parameters

Humans use Plain Text format

Computers use special error correcting format

Local CRT has special commands



PROGRAM MODULES

RTUMON.EXE

Main DOS program Module

Controls all RTU processes

Multi-Tasks under DOS

RTUMON.OVR

Contains startup procedures and functions used by local CRT

Must be matched to EXE file

May be on separate fast drive

CONFIG FILES

Tells program about each individual location setup for RTU and location related information



COMM LINKS

Combination of physical and logical connection between RTU and Host Systems

Can be by Radio, Phone, or Direct Connection

Allows for real world comm problems for offshore

Extensive error detection and correction



IDLE TASK

Required by Multi-Tasker

Fills any idle CPU time

Automatically allocated by system at startup

Always last assigned task

Cannot be stopped



TYPICAL SETUP

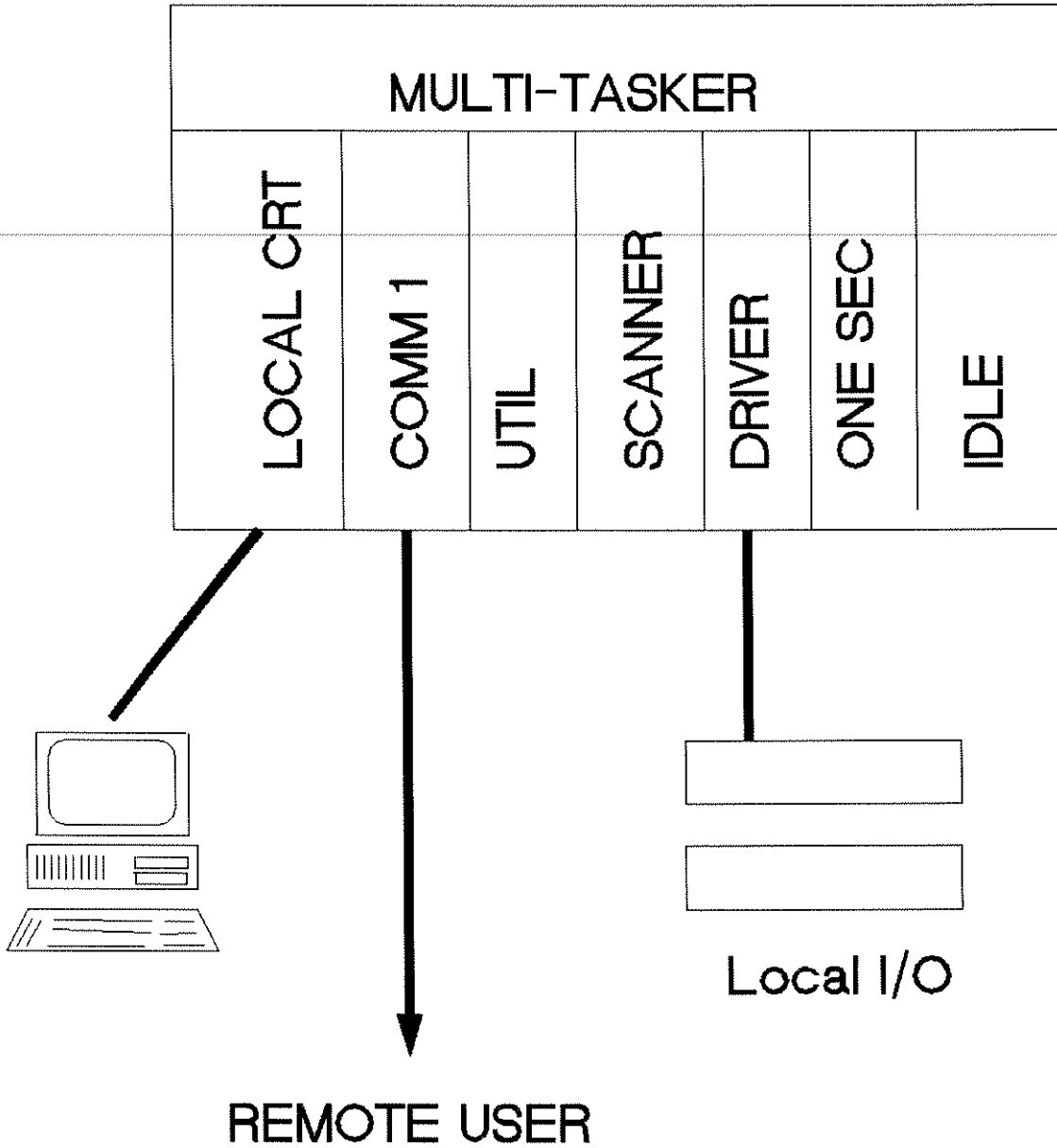

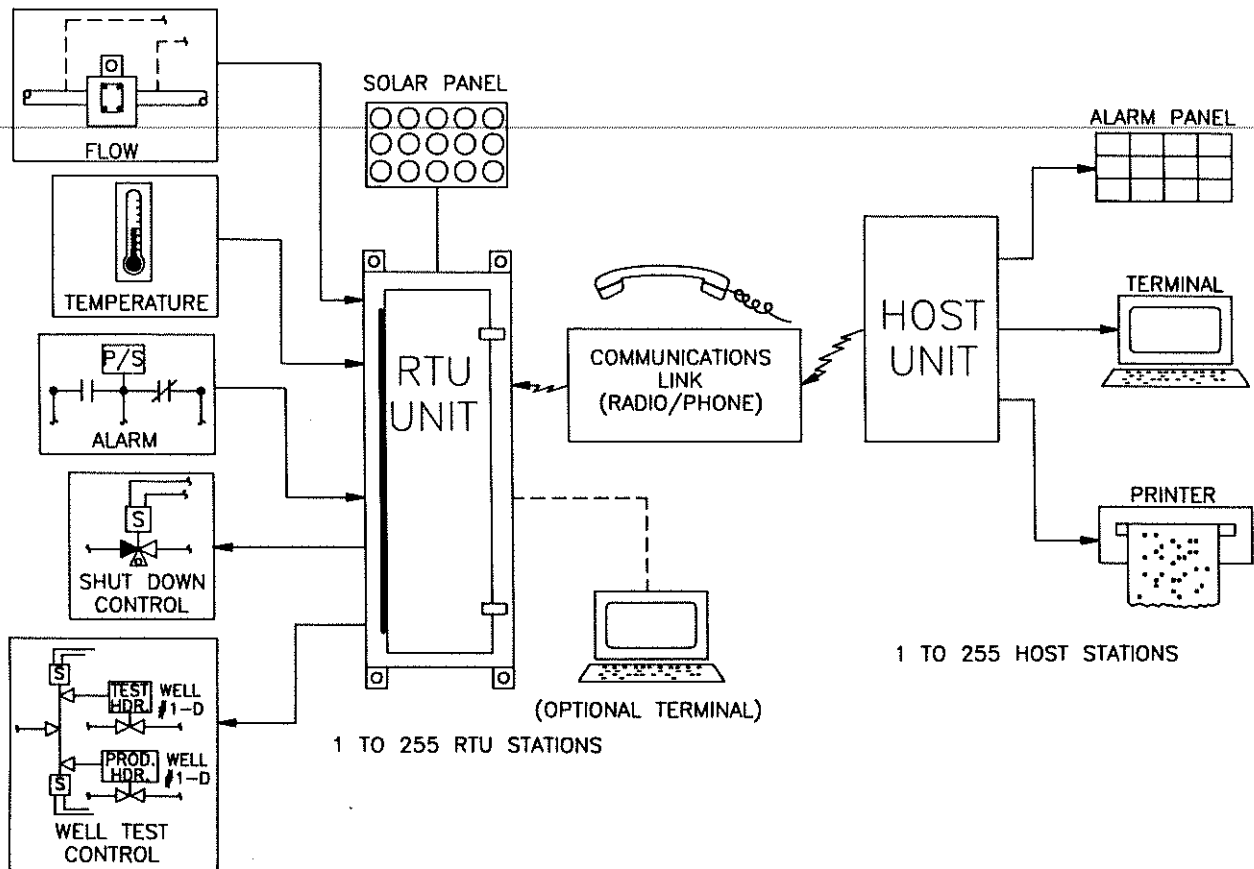

LOGICAL RTU

Each "RTU" is a Group
of Channels in System List

Independent of Each Other

Remote or Local Status

Data is Time Stamped

Individual Config Files



RTU to HOST SETUP XFER

Each RTU Has Separate
Setup Text File

Need to Modify Channel
Config for HOST Mode

CHANGE Command Simplifies
Changes to Point Groups

Some Features Automatically
Changed via HOST/RTU Status



GA343A TIMER CHANNEL 1 Of 8 REMOTE

Channel Name	SSV Shutdown Pulse	Up Counter?	N
Tag	T1	Timing State ON?	Y
Alarm Delay Secs	0	Start Channel	
Alarm Type Channel?	N	Output Channel	01-343
Blow Horn on Alarm?	N	Auto Output ?	N
Reset After ACK?	Y	Auto Reset?	Y
Call on Abnormal?	N		
Call on Reset?	N		
Log Abnormals?	N		
Execute RTU file?	N		
Skip Reports?	N		
Callout Group	1		
Units	Secs		
Input Control Channel			
Lo Alarm Value	0		
Hi Alarm Value	20		
Dead Band	0		

<F2> Save <PgUp> Previous Channel <PgDn> Next Channel <Esc> Cancel |

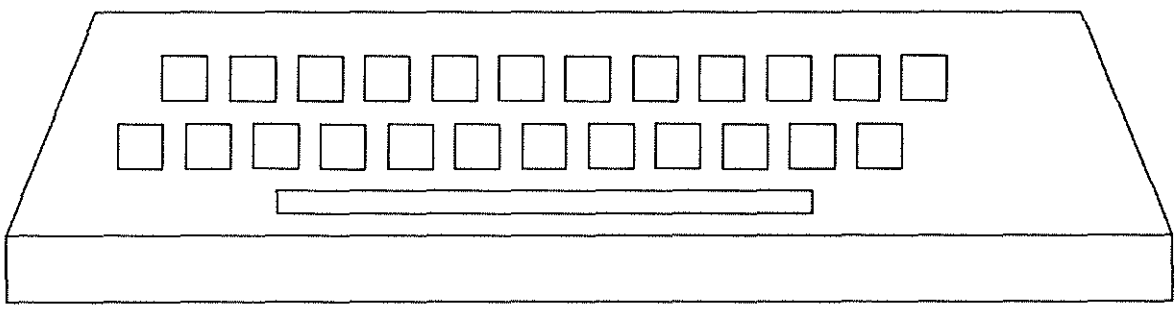

STATUS OUTPUT

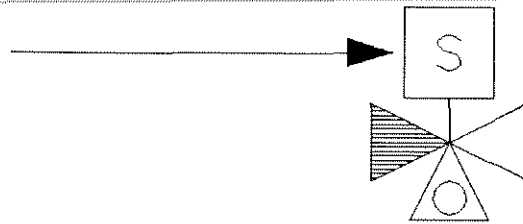

Inherits Channel Basics
Inherits Status Basics

Normally Energized?

May be tied to Timer

CHANNEL SETUPS

Describe Points to System

Normally Done on RTU Itself

Setup Screen for Each
Different Channel Type

Easy RTU Duplication

Setups Stored in DOS
ASCII Text File



DATA TRANSFER OPTIONS

Field Adjustable for Each
RTU and COMM Link

Optimized for Phone or Radio

Either HOST or RTU can
Control Transfers

DOWNLOAD File Normally Used

Default Action Based on
HOST or RTU Status



LOGICAL RTU SETUP

RTU ID (8 Chars)

Number of Channels

Remote/Local Status

Default Comm Link

Optional Menu Files

Optional Custom Display



RTU CHANNEL TYPES

REAL CHANNELS

Status Inputs
Status Outputs
Analog Inputs
Counter Inputs

LOGICAL CHANNELS

Values
AGA-3 Meters
Totalizers
Timers
Frequency (rate)



RTU CHANNELS

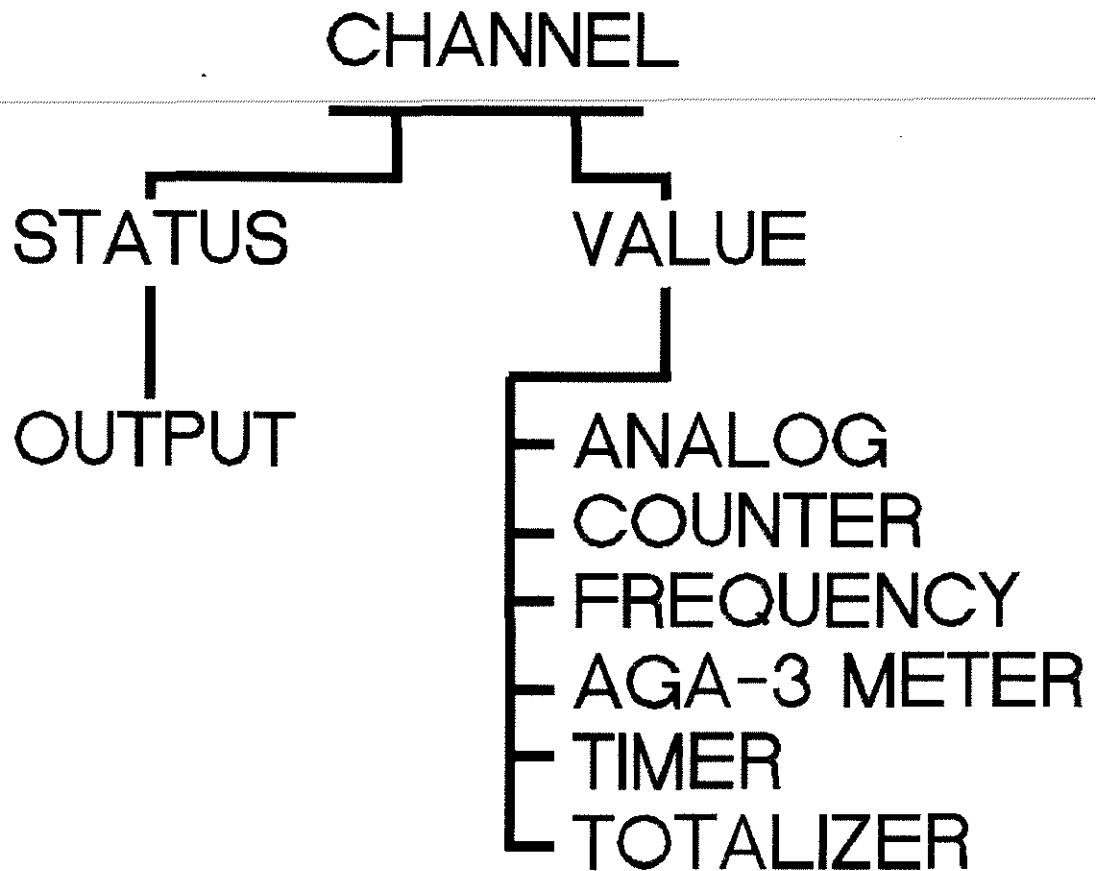

CHANNEL BASICS

Channel Name

TAG

Alarm Delay (Seconds)

Alarm Type?

Blow Horn on Alarm?

Reset after ACK?

Call on Abnormal?

Call on Reset?

Log Abnormals?

Execute RTU File?

Skip Reports?

Callout Group



ALARM STATES

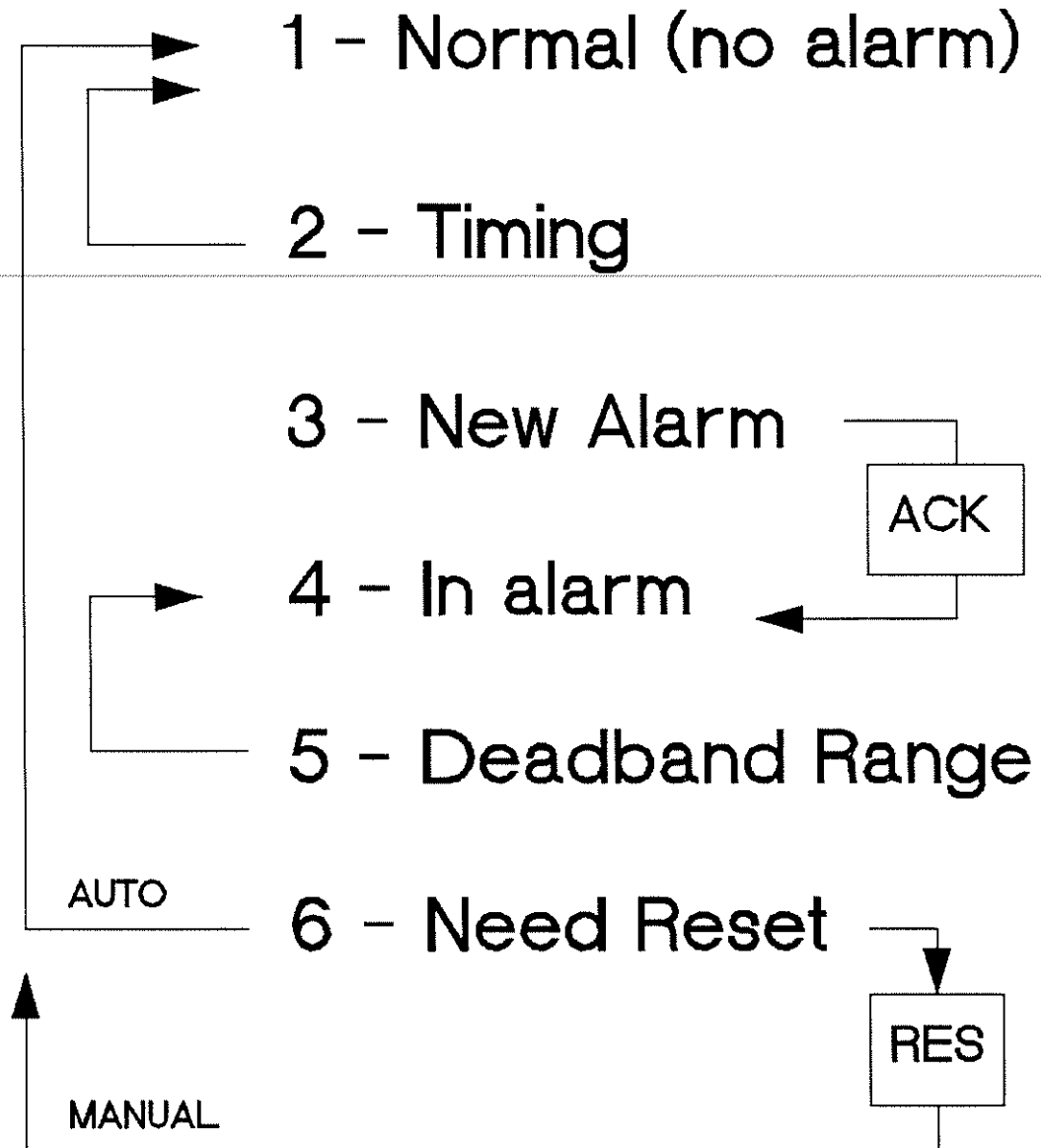

CHANNEL REFERENCES

Point ID A5, Q3, O2

TAG PSL110, TOTAL, NAVBAT

Single or Group Reference

Current RTU is Default

RTU can be specified with
RtuName.CH1:CH2

VR256.S1:s8



STATUS INPUT

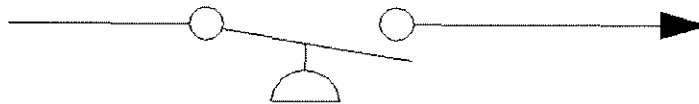

Inherits Channel Basics

Normal State Text

"Platform Running"

Abnormal State Text

"Platform Shut-In"

Normal State is ON?



GA343A

OUTPUT CHANNEL

1 Of 4

REMOTE

Channel Name	SSV Shutdown
Tag	01-343
Alarm Delay Secs	0
Alarm Type Channel?	N
Blow Horn on Alarm?	N
Reset After ACK?	N
Call on Abnormal?	N
Call on Reset?	N
Log Abnormals?	N
Execute RTU file?	N
Skip Reports?	N
Callout Group	1
Normal Text	Not Active
Abnormal Text	ACTIVE
Is Normal State ON?	N
Normally Energized?	N

<F2> Save <PgUp> Previous Channel <PgDn> Next Channel <Esc> Cancel |

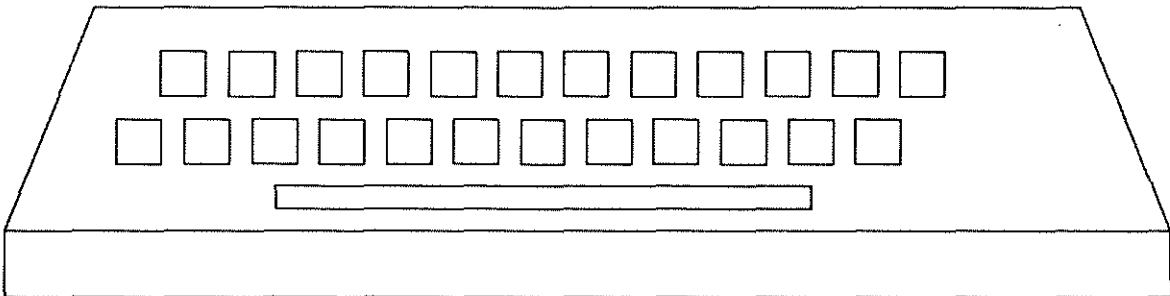

VALUE CHANNELS

1234.567

Inherits Channel Basics

Units (Volts, PSI, DEG-F)

Input Control Channel

Low Alarm Value

High Alarm value

Dead Band (Hi and Lo)



GA343A VALUE CHANNEL 1 Of 16 REMOTE

Channel Name	Gas Sales #1 Plate
Tag	PLATE1
Alarm Delay Secs	0
Alarm Type Channel?	N
Blow Horn on Alarm?	N
Reset After ACK?	N
Call on Abnormal?	N
Call on Reset?	N
Log Abnormals?	N
Execute RTU file?	N
Skip Reports?	N
Callout Group	1
Units	Inches
Input Control Channel	
Lo Alarm Value	0
Hi Alarm Value	10
Dead Band	0

<F2> Save <PgUp> Previous Channel <PgDn> Next Channel <Esc> Cancel

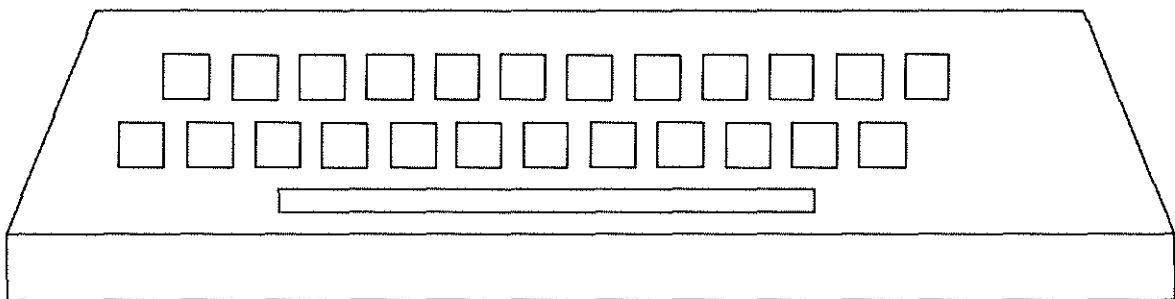

ANALOG INPUTS

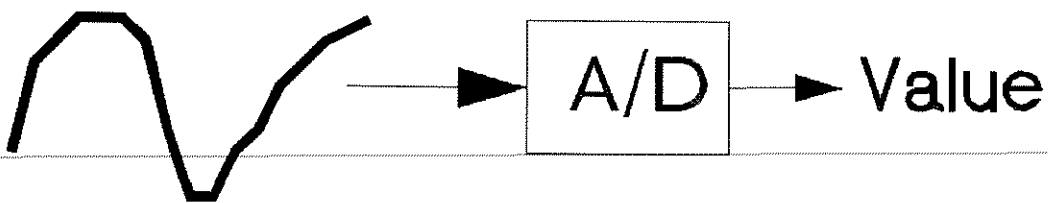

Inherits Channel Basics
Inherits Value Basics

Offset Channel?
Value at 0%
Value at 100%
Allow Negative?

Used for Pressure, Temp,
Level, Etc.



GA343A

ANALOG CHANNEL

4 OF 16

REMOTE

Channel Name	H.P. Separator Press	Offset Channel?	Y
Tag	PT300	Value at 0%	0
Alarm Delay Secs	10	Value at 100%	1500
Alarm Type Channel?	N	Allow Negative?	N
Blow Horn on Alarm?	Y		
Reset After ACK?	Y		
Call on Abnormal?	Y		
Call on Reset?	Y		
Log Abnormals?	N		
Execute RTU file?	N		
Skip Reports?	N		
Callout Group	1		
Units	Psig		
Input Control Channel			
Lo Alarm Value	800		
Hi Alarm Value	1600		
Dead Band	0		

<F2> Save <PgUp> Previous Channel <PgDn> Next Channel <Esc> Cancel |

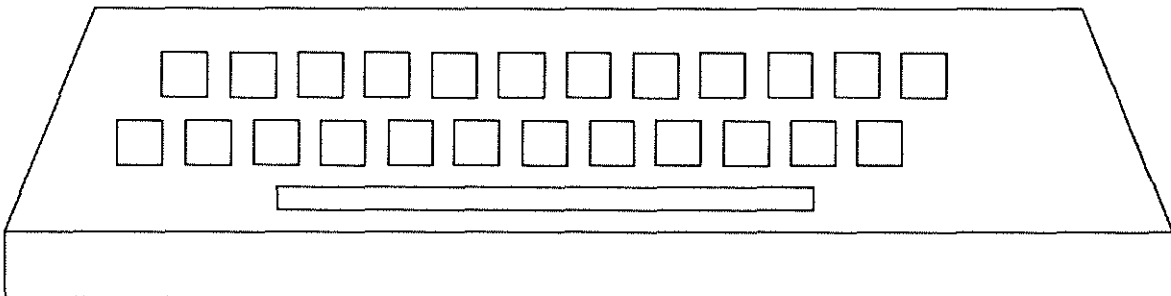

COUNTER INPUTS

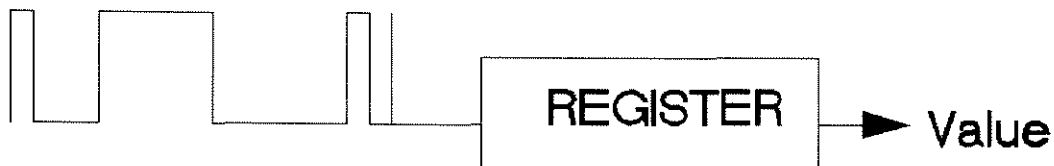

Inherits Channel Basics
Inherits Value Basics

Threshold Count

How many ticks = 1 unit

Counter Factor

Multiply each unit for value

Filter Ticks

Eliminate stray counts

Used for meters



GA343A COUNTER CHANNEL 1 of 8 REMOTE

Channel Name	Produced Water	Threshold Count	1
Tag	FQI401	Counter Factor	0.1
Alarm Delay Secs	0	Filter Ticks	3
Alarm Type Channel?	N		
Blow Horn on Alarm?	N		
Reset After ACK?	N		
Call on Abnormal?	N		
Call on Reset?	N		
Log Abnormals?	N		
Execute RTU file?	N		
Skip Reports?	N		
Callout Group	1		
Units	Bbls		
Input Control Channel			
Lo Alarm Value	0		
Hi Alarm Value	999999		
Dead Band	0		

<F2> Save <PgUp> Previous Channel <PgDn> Next Channel <Esc> Cancel |

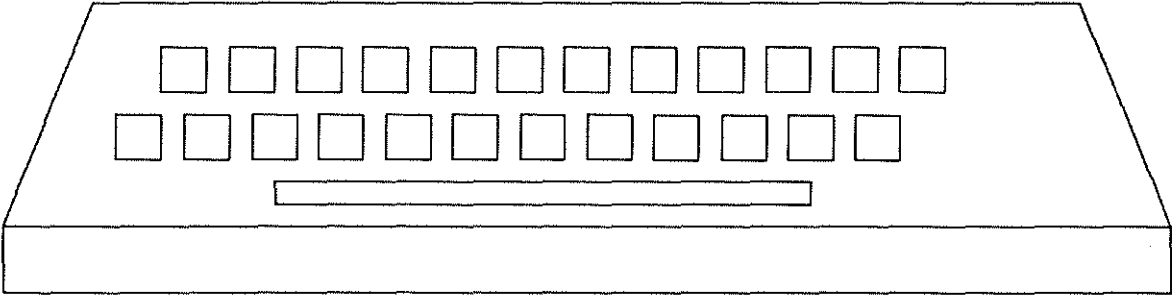

FREQUENCY (RATE) INPUT

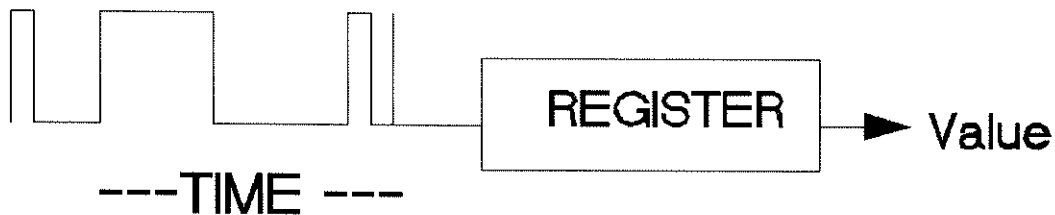

Inherits Channel Basics
Inherits Value Basics

Measures Input over Time

Specify Input Channel
Factor accounts for units
Sample Period in Seconds

GA343A FREQUENCY CHANNEL 1 Of 4 REMOTE

Channel Name	Current Flow Rate	Input Chan	FQI401
Tag	FRATE	Freq Factor	1
Alarm Delay Secs	0	Sample Secs	10
Alarm Type Channel?	N		
Blow Horn on Alarm?	N		
Reset After ACK?	N		
Call on Abnormal?	N		
Call on Reset?	N		
Log Abnormals?	N		
Execute RTU file?	N		
Skip Reports?	N		
Callout Group	1		
Units	Cps		
Input Control Channel			
Lo Alarm Value	-1		
Hi Alarm Value	999999		
Dead Band	0		

<F2> Save <PgUp> Previous Channel <PgDn> Next Channel <Esc> Cancel |

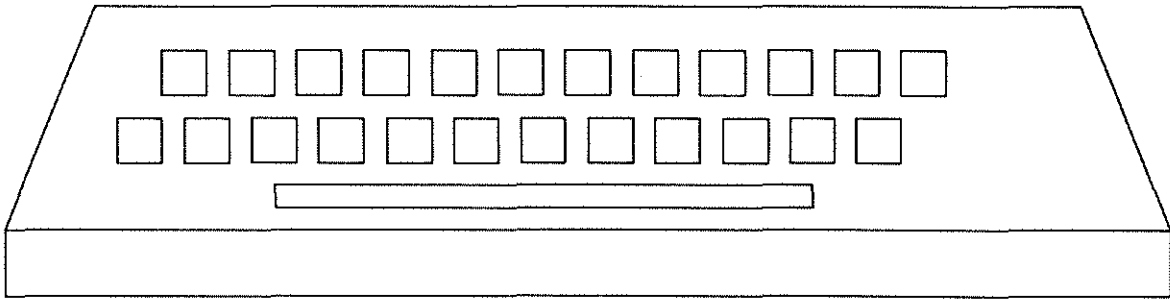

GA343A

STATUS CHANNEL

1 Of 8

REMOTE

Channel Name	Skimmer
Tag	LSH400
Alarm Delay Secs	2
Alarm Type Channel?	Y
Blow Horn on Alarm?	Y
Reset After ACK?	Y
Call on Abnormal?	Y
Call on Reset?	N
Log Abnormals?	Y
Execute RTU file?	N
Skip Reports?	N
Callout Group	1
Normal Text	In Service
Abnormal Text	Shutdown
Is Normal State ON?	Y

<F2> Save <PgUp> Previous Channel <PgDn> Next Channel <Esc> Cancel |

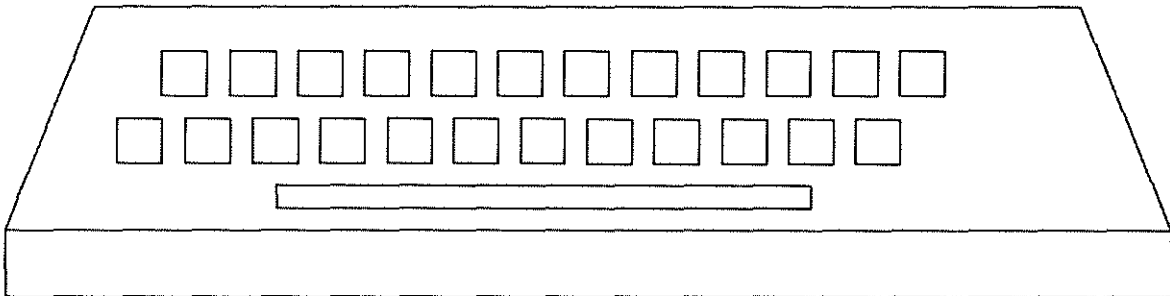

GAS FLOW MEASUREMENT

AGA-3 Gas flow calculation

Uses Delta-P, Static P, and Temp

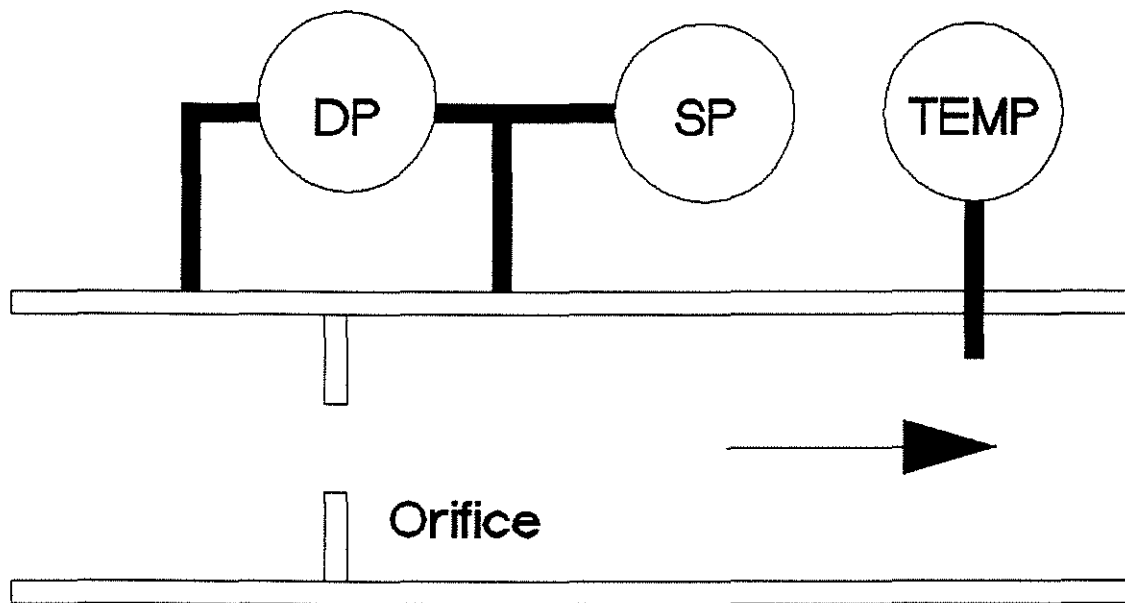

A006

AGA-3 GAS METERS

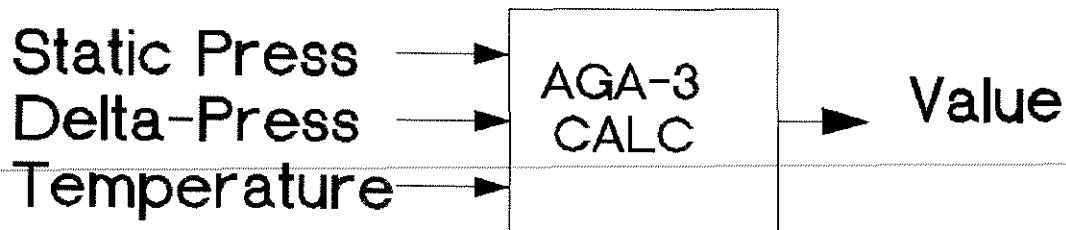

Inherits Basic and Value Chans.

Press, Delta-P, Temp, Plate,
MCO2, MN2 from any channel.

Deg C or F, Up-Down Stream,
Pile or Flange, Stainless or
Monel, Height, Latitude

Contract Temp and Pressure

Adjustable Recalc Freq



GA343A AGA3 CHANNEL 1 Of 3 REMOTE

Channel Name	Channel M1	Plate Channel	PLATE1
Tag	M1	Diff Channel	DPT901
Alarm Delay Secs	0	Static Channel	PT901
Alarm Type Channel?	N	Is Press PSIG?	Y
Blow Horn on Alarm?	N	Temp Channel	TT901
Reset After ACK?	N	Temp in Deg-F?	Y
Call on Abnormal?	N	S.G. Channel	SG
Call on Reset?	N	MCO2 Channel	MCO2
Log Abnormals?	N	MN2 Channel	MN2
Execute RTU file?	N	Conv Factor	41.667
Skip Reports?	N	Height in Feet	70
Callout Group	1	Latitude	30
Units	MCF/Hr	Tap Upstream?	Y
Input Control Channel		Pipe Tap?	N
Lo Alarm Value	-1	Stainless?	Y
Hi Alarm Value	9999999	Temp Base	60
Dead Band	0	Pres Base	14.7
Pipe Diameter	3	Recalc Freq	1

<F2> Save <PgUp> Previous Channel <PgDn> Next Channel <Esc> Cancel |

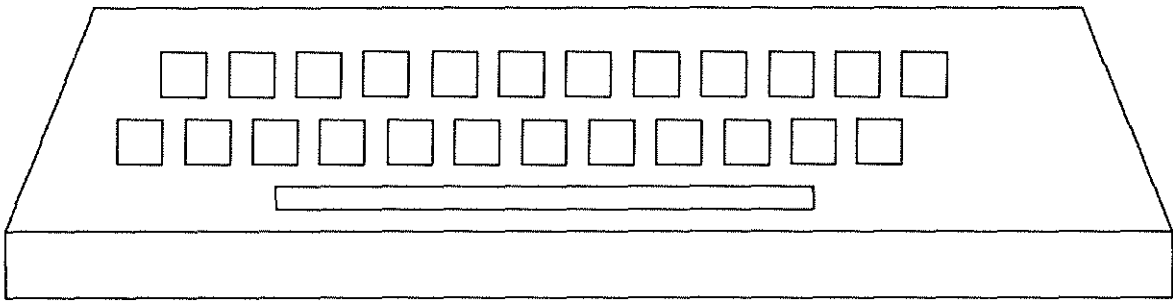

TOTALIZERS

$$\text{TOTAL} = \text{TOTAL} + \frac{\text{SAMPLE}}{\text{FACTOR}}$$

Inherits Basics + Values

Samples Each Second

Factor Divided into Sample

Minimum Acceptable Input

Used for Total Gas Volume



GA343A TOTALIZER CHANNEL 1 Of 4 REMOTE

Channel Name	Sales Gas Meter #1	Input Channel	M1
Tag	Q1	Min Value	0
Alarm Delay Secs	0	Factor	86400
Alarm Type Channel?	N		
Blow Horn on Alarm?	N		
Reset After ACK?	N		
Call on Abnormal?	N		
Call on Reset?	N		
Log Abnormals?	N		
Execute RTU file?	N		
Skip Reports?	N		
Callout Group	1		
Units	MMCF		
Input Control Channel			
Lo Alarm Value	0		
Hi Alarm Value	100		
Dead Band	0		

<F2> Save <PgUp> Previous Channel <PgDn> Next Channel <Esc> Cancel |

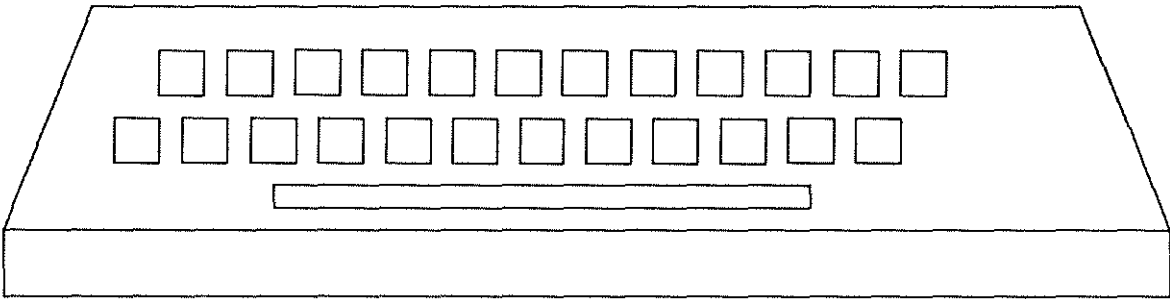

TIMERS

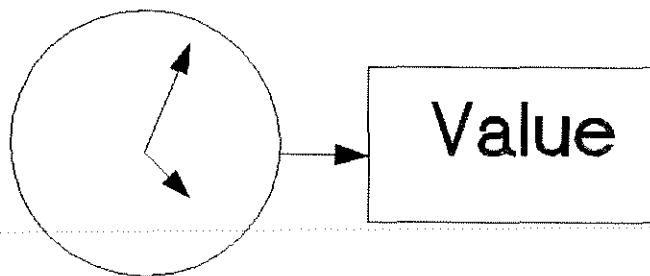

Inherits Channel Basics

Inherits Value Channel

Can count Up or Down

Alarm at Time or Zero

Hrs, Mins, or Secs

Any channel can start/control

Can directly control output

RTU CHANNELS

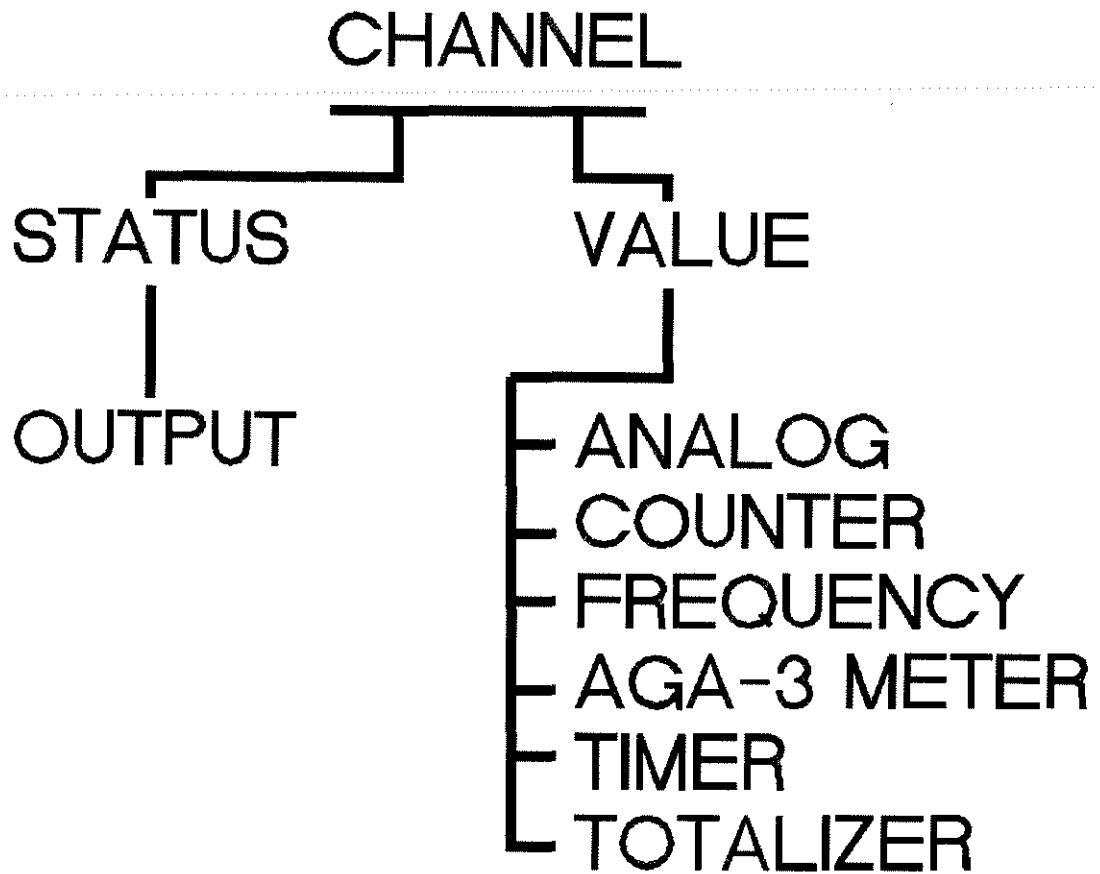

RTU CHANNEL TYPES

REAL CHANNELS

Status Inputs

Status Outputs

Analog Inputs

Counter Inputs

LOGICAL CHANNELS

Values

AGA-3 Meters

Totalizers

Timers

Frequency (rate)



COMMUNICATIONS

RTU to HOST Connections

Serial Data Transmission
of Digital Information

Hard Wire Electrical

Audio Tone via Telephone
or Radio Links

On-Line or Dial-Up Link

Error Prone Technology



COMMUNICATION TERMS

Simplex - Duplex

Half - Full Duplex

Originate - Answer

2 Wire - 4 Wire

Echo

Parity - Odd, Even, None, Mark

Start and Stop Bits

Baud Rate



DIAL-UP VS. DIRECT

Many Systems Require Direct Connection by Design

Direct is Easy and Fast

Dial-Up Presents Many Problems

Most Transfer Time is Spent Making the Connection

Dial-Up is Much Cheaper

Dial-Up uses Less Power



RS-232 STANDARD

Recommended Standard
Pins and levels only

DTE and DCE Varieties

Not related to Data

Protective Ground	1	14	
Transmit Data	2	15	
Receive Data	3	16	
Request to Send	4	17	
Clear to Send	5	18	
Data Set Ready	6	19	
Signal Ground	7	20	Data Terminal Ready
Carrier Detect	8	21	
	9	22	Ring Indicator
	10	23	
	11	24	
High Speed	12	25	
	13		

DCE - MODEM

DB-25



PROTOCOLS

Language of communications

Formed by Industry

Formal and Informal

Not tied to Hardware

Constantly evolving

XMODEM, MAP, MODBUS, TIWAY



ASCII DATA

American Standard Code for
Information Interchange (ASCII)

Binary codes for Text

Also Control Codes

Worldwide Standard

7 bits - 128 chars

8 bits - 256 chars (USASCII)



DATA TRANSFERS

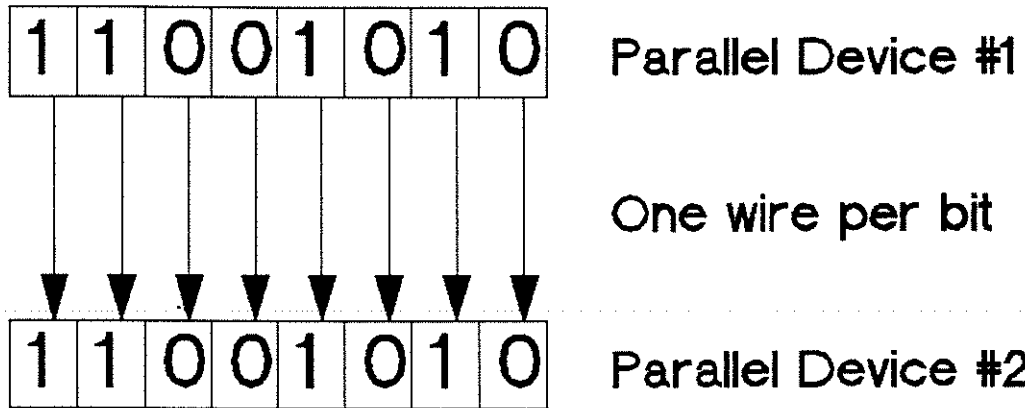

PARALLEL TRANSFERS

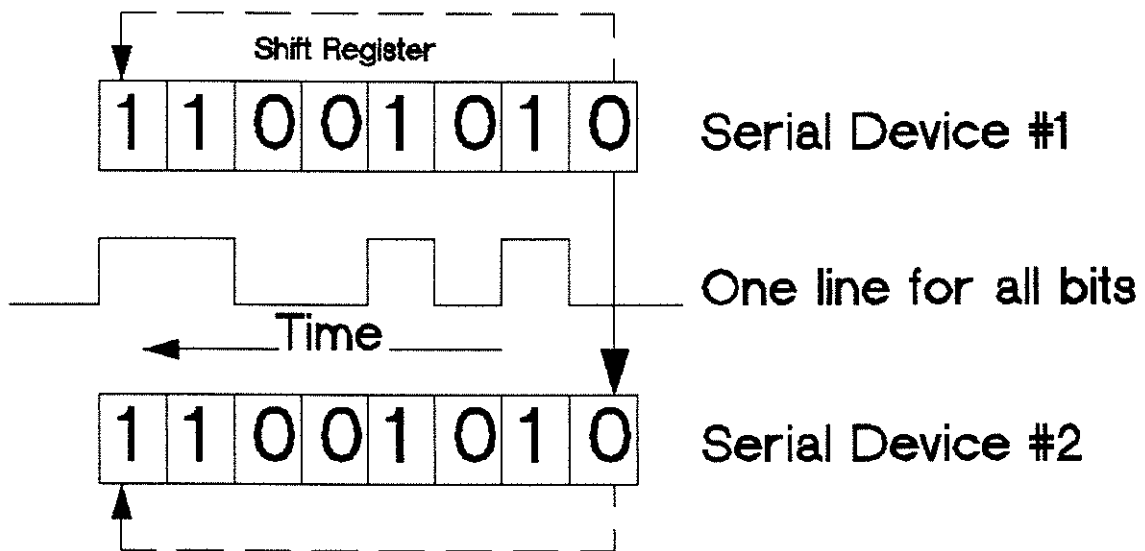

SERIAL TRANSFERS



SERIAL DATA

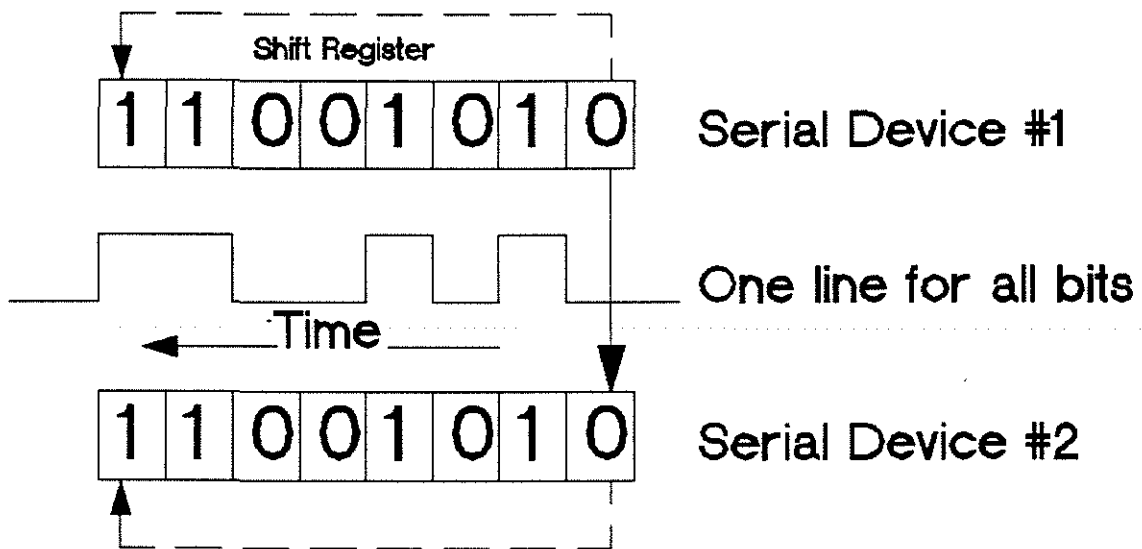

Data not valid during xfer

Only one comm path required

Slower than Parallel

Any distance possible



SERIAL COMM

Synchronous or Async

Normally 8 data bits

Start and Stop bits

Parity Bits

Baud Rate (Bits/sec)

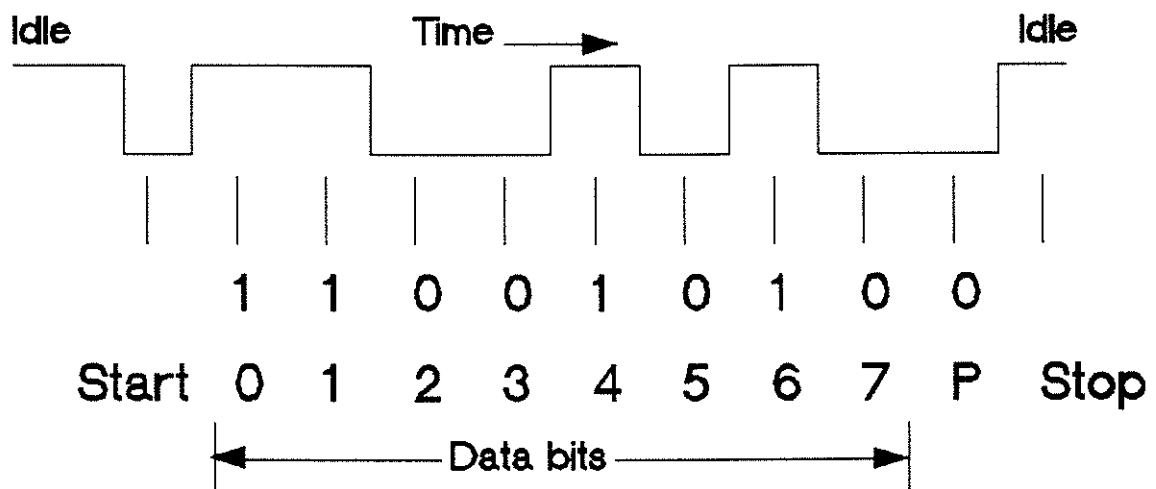

COMM SECURITY



Detect Transmission Errors

Required in Industrial Systems

Difficult in Dial-Up Systems

Normally Uses "Checksum"

System Reactions Vary

Automatic Retry and Timeout



PHONE SYSTEMS

Various Technologies

Wireline, Cellular, Radio

Signal Can Vary From One
Call to Another

Phone Carries Audio Modem
Signals for 1 and 0

System Maintained by Others



DATA MODEMS

MOdulator - DEModulator

Changes 1/0 to tones

Changes tones to 1/0

Many industry standards

Both ends must match

Getting complicated



RADIOS

Electromagnetic Radiation

Microvolt levels

Limited reliability

Each band has characteristics

Radio carries modem tones

Normally half duplex



RADIO RANGES

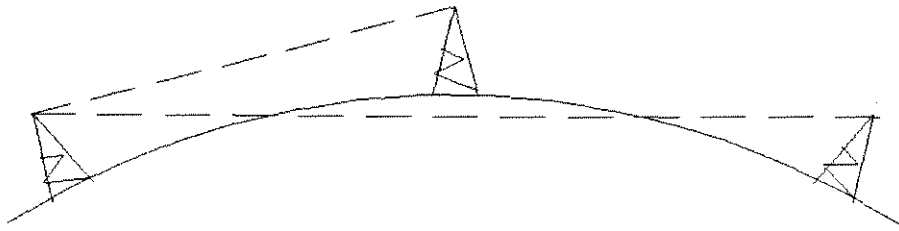

Antenna Height Gives Range

Lower Freq Follows Curve

Higher Freq is Line of Sight

Open Water is Good and Bad



PACKET RADIO CONTROLLER

Acts as Very Smart Modem
for Radio Systems

Each has Unique "Callsign"

Sends Tones to Radio via
Microphone Input

Receives Tones from Radio
via Speaker Output

Keys Radio and waits for Xmit

Provides Routing, Error Checks,
FCC Timeouts, other tricks



COMM LINKS

Combination of physical and logical connection between RTU and Host Systems

Can be by Radio, Phone, or Direct Connection

Allows for real world comm problems for offshore

Extensive error detection and correction



DEMO RTU SYSTEM

Manned

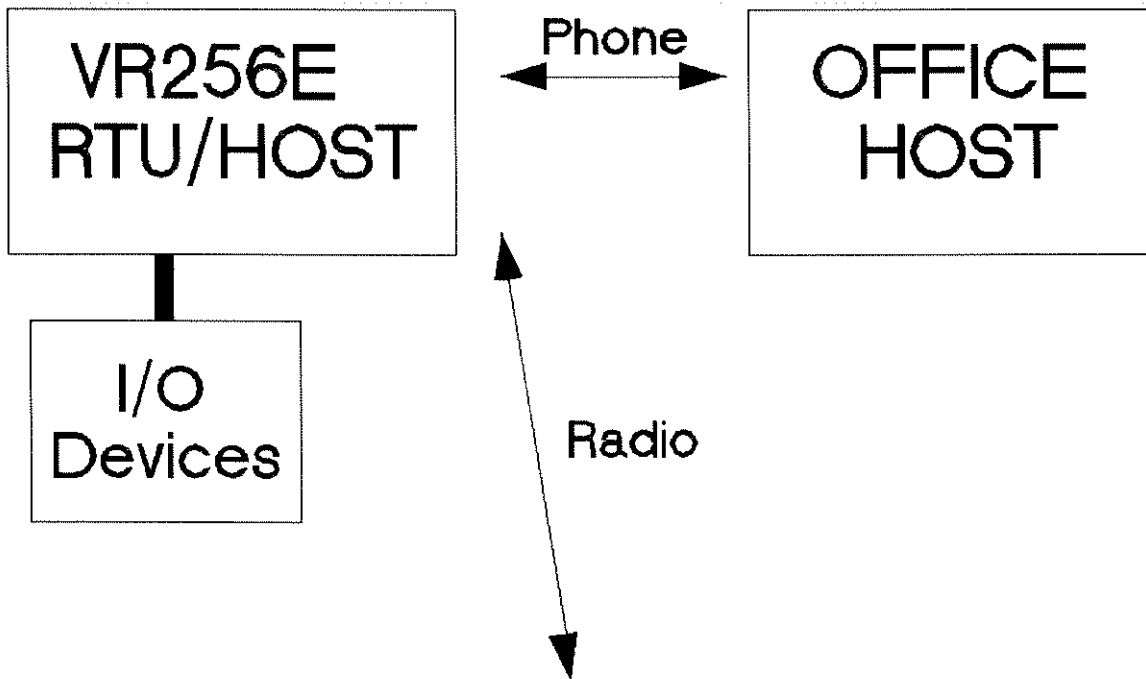

Unmanned

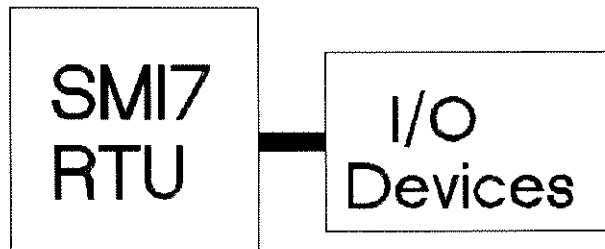

FREQUENCY COORDINATION

Government Regulated via CFR
Part 90 and Coord. Committee

Distribute Frequencies Among
Various "Services"

Petroleum Radio Service

Share Channels with Groups
Not Normally Close

Various License Types



AM - FM TRANSMISSION

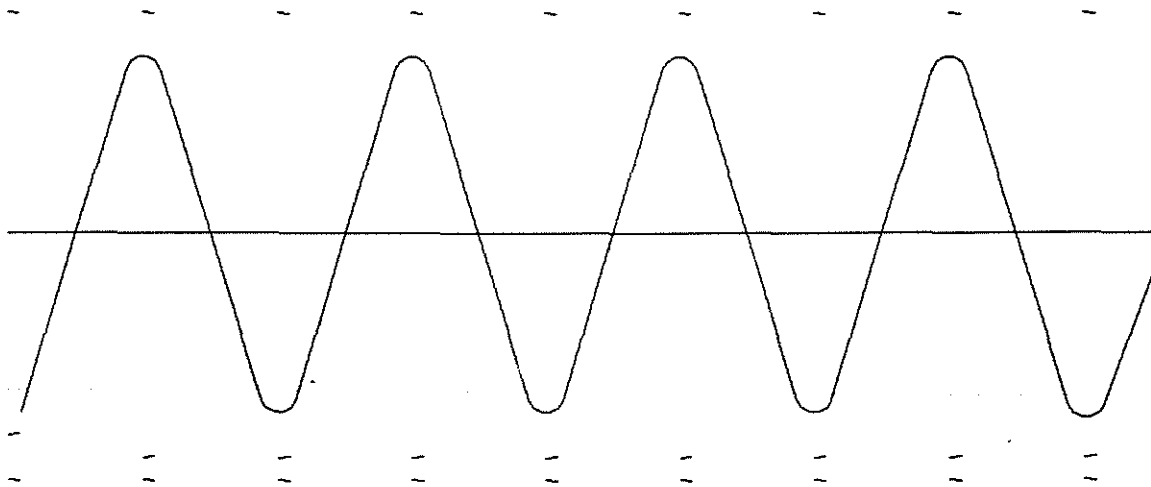

AM

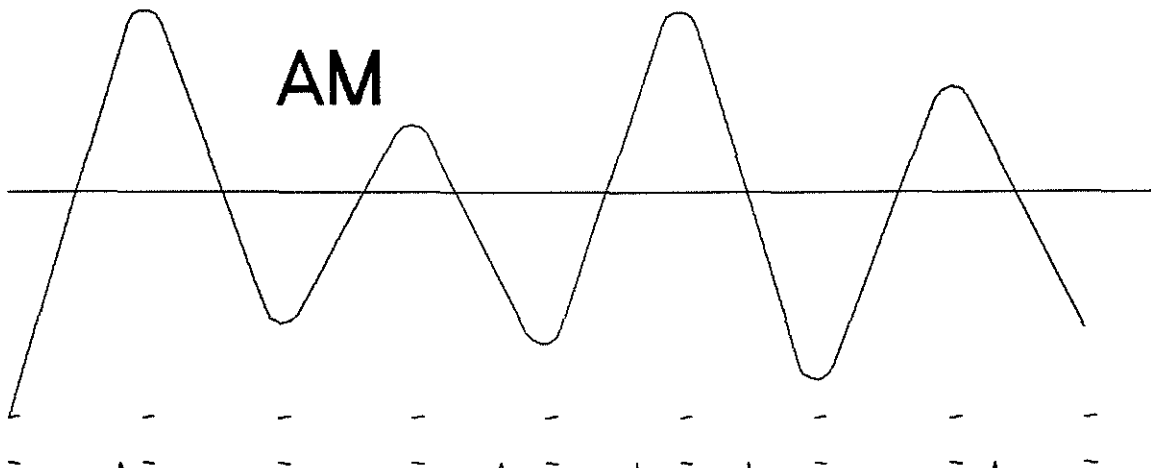

FM



COMMUNICATIONS PROBLEMS

Total Equipment Failure

Periodic Interference

Continuous Interference

Equipment Changes

Maintenance



LINK 1 Of 4

Task Number 1
Phone Number 555-1212
Max Call Trys 3
Giveup Secs 60
Wait Secs 60
Is this a Host? N

<F2> Save <PgUp> Previous Link <PgDn> Next Link <Esc> Cancel

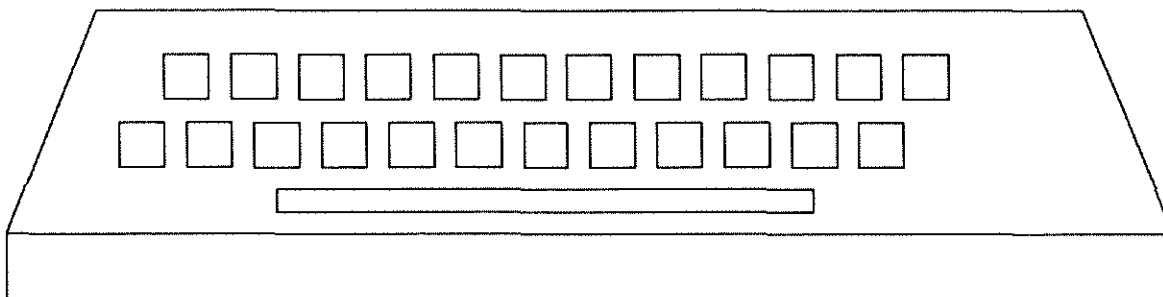

GA343A SYSTEM STATUS 11:54:34

COMMUNICATIONS LINK STATUS

LNK	TASK	HOST	TRYS	CUR	WAIT	LEFT	GIVUP	STATUS	NUMBER
1	1	No	3	0	60	0	60	Idle	555-1212
2	2	No	3	0	60	0	60	Idle	VR256E
3	1	No	3	0	120	0	60	Idle	SMI7
4	2	No	3	0	180	0	45	Idle	555-1212

TASK	LINK	CALLING	ONLINE	TIMER	CMD	RESET	INPUT	ACK
1	0	No	No	0	0	2859	0	0

[ESC] to STOP

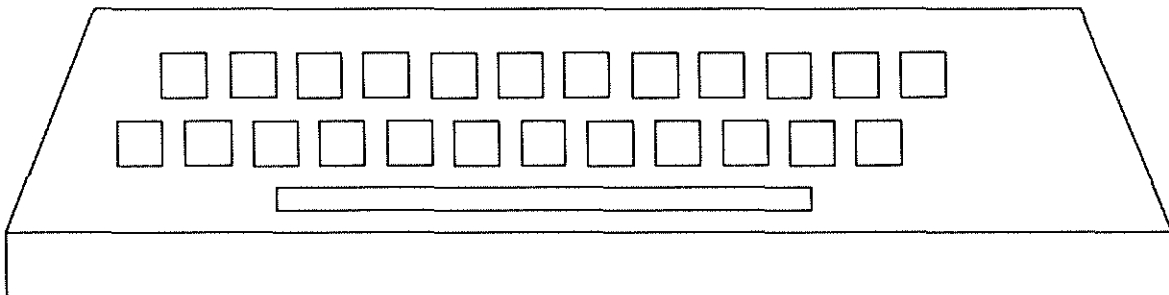

GA343A SYSTEM STATUS 11:47:29

TSK	STATE	TICKS	LEFT	DELY	LEFT	TASK NAME	ONLINE	CUR	RTU	LAST	CMD	CMD	NUM
0	RUNNING	2	2	2		Local CRT	Yes	GA343A		STAT			0
1	waiting	2	2	2	1	Com1 Radio	No	GA343A		HAYES			0
2	waiting	2	2	4	1	Utility RTU	No	GA343A		READ			0
3	waiting	1	1	4	3	Alarm Scan							
4	waiting	1	1	2	1								
5	waiting	2	2	4	1	Calculator	No	GA343A		READ			0
6	WAITING	16	16	2		One Second							
7	SUSPEND	1	1	2		Idle Task							

TASK	LINK	CALLING	ONLINE	TIMER	CMD	RESET	INPUT	ACK
1	0	No	No	0	0	3285	0	0

COMMUNICATIONS CHANNEL STATUS

COM	INCNT	OUTCNT	ONLINE	FORCE	BRKS	MAX	INT	STAT	CTL	IID	PORT	VEC
1	0	0	No	0	0	1	70	30	0B	01	03F8	0C

DISP= 573 RTC= 0 BIOS= 7598

[ESC] to STOP

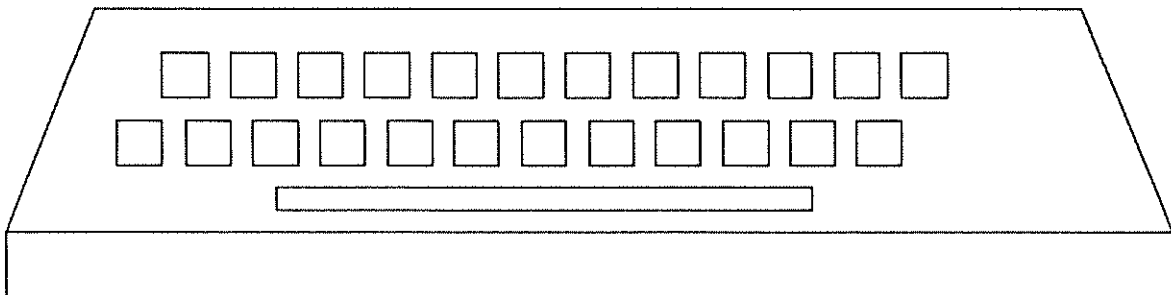

MICROWAVE SYSTEMS

"Microwave" covers Frequencies > 1,000 Mhz

**Strictly Line-of-Sight Transmission with Towers
Required Every 10-20 Miles (16-32 Km)**

Signal affected by atmospheric conditions.

**Typical systems Cost Effective only in High-
Capacity Applications**

**External, Modular Interfaces for Audio, Phone, and
Digital Circuits.**

**Each circuit has combined sub-circuits (channels)
with a specific signal bandwidth. Adjacent channels
can be combined for high-demand applications such
as real-time video.**

LB-100 VOICE RTU

Status Input/Output RTU

Digitized Voice Messages

DTMF (Touch Tone) Operation

Two Way Phone Operation

One Way Radio Operation

All Programming by TEST



IB-24 TOUCH TONE RTU

Status Output Only

Voice Radio Operation

Very Low Power Operation

All Programming by TEST

Normally used to Pulse Outputs



TEST RTU SYSTEMS

- | | |
|-----------|---|
| Type 1000 | Large Scale "Smart" SCADA
Using AMPRO/Metrabus I/O
Works with TEST Software |
| Type 1200 | Med Scale "Smart" SCADA
Using AMPRO/TEST Inc. I/O
Works with TEST Software |
| Type 2000 | Med Scale "Dumb" SCADA
Uses MicroMint Components
Works with TEST Software |
| Type 100 | Small Scale Voice RTU
Provides Status I/O Only
Works with Touch Tone Codes |
| Type 24 | Small Scale Radio RTU
Provides Status Output Only
Works with Touch Tone Codes |



TEST RTU DESIGN

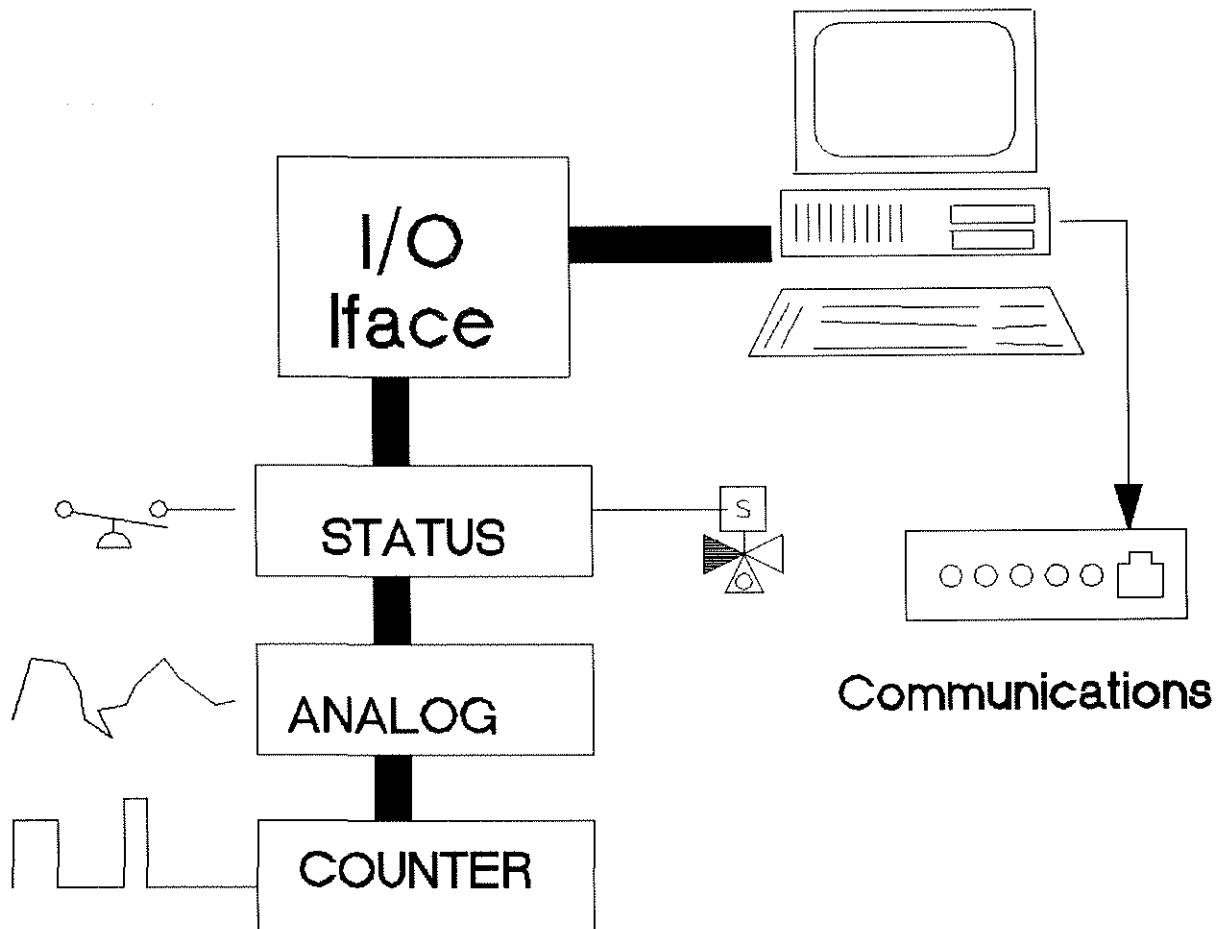

TYPE 1000 RTU

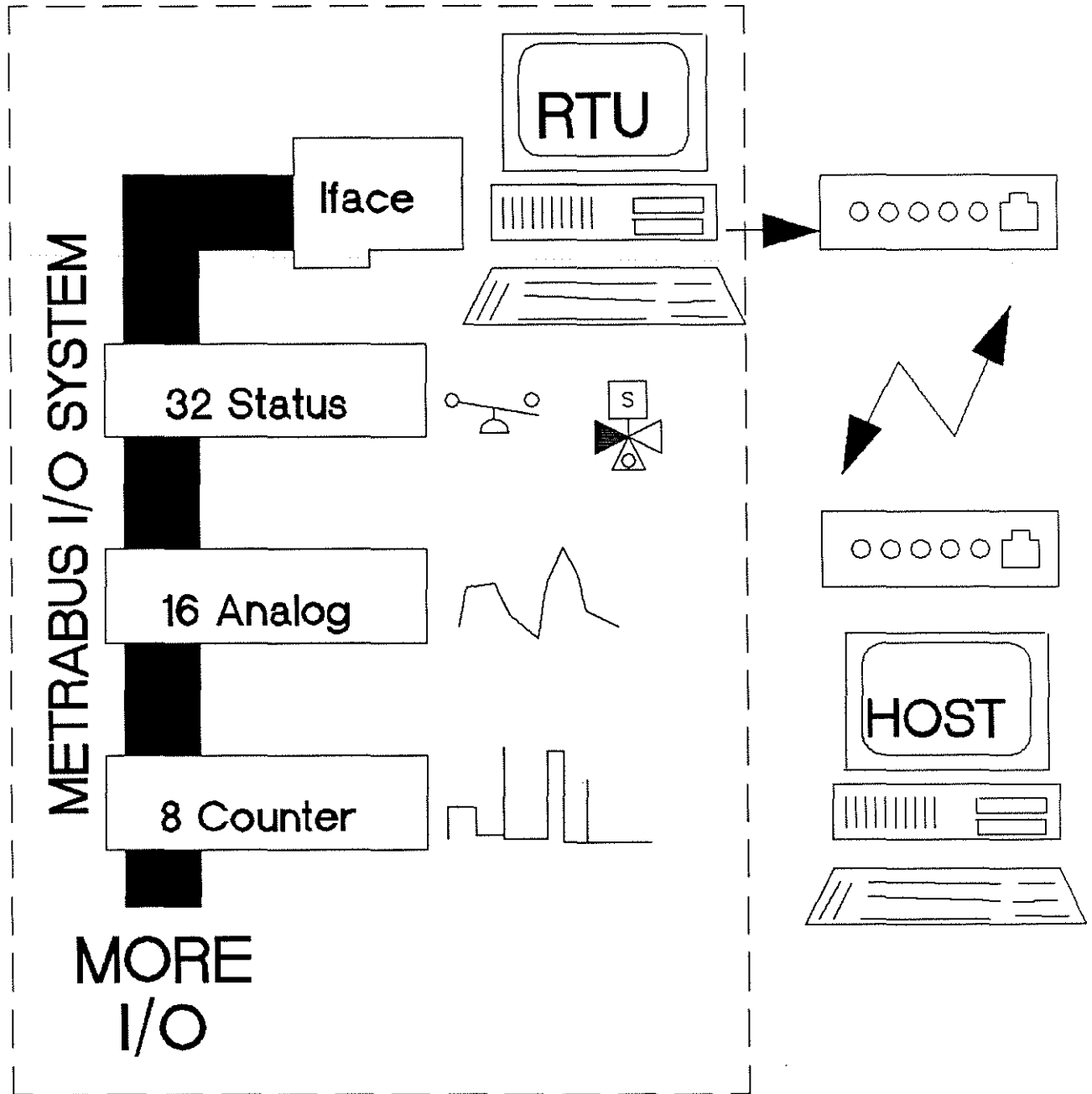

TYPE 1200 RTU

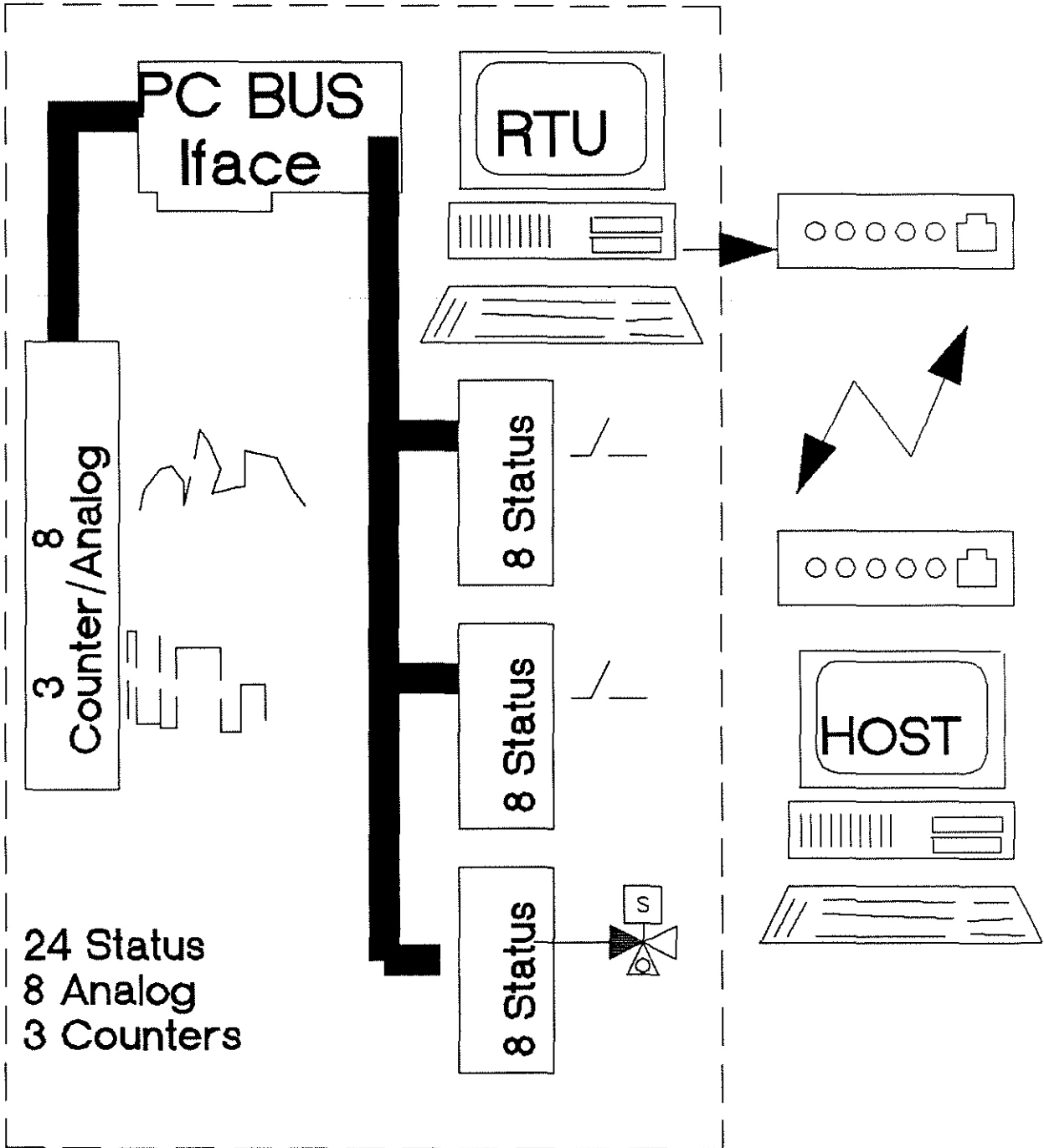

TYPE 2000 RTU

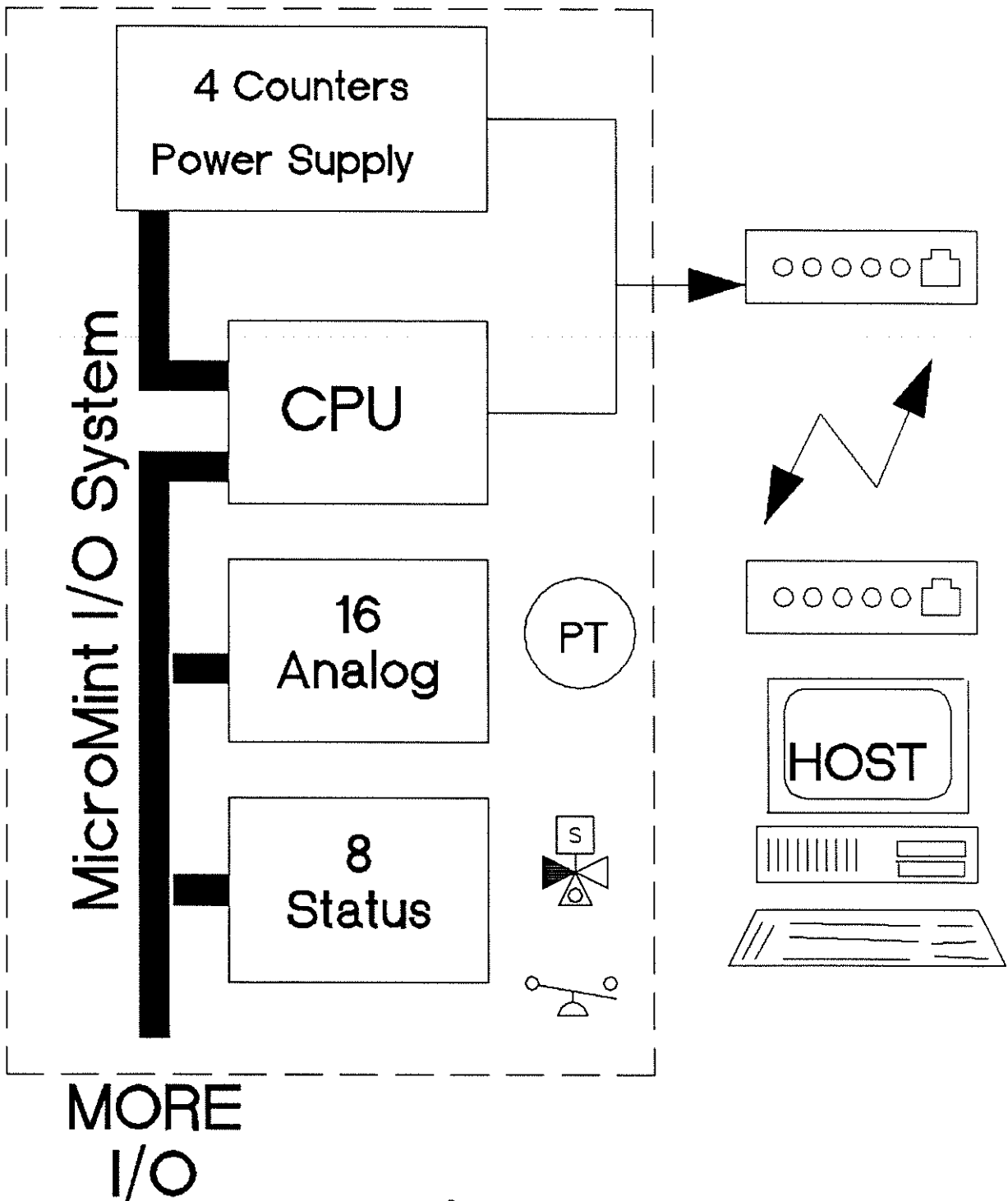

TYPE 100 RTU

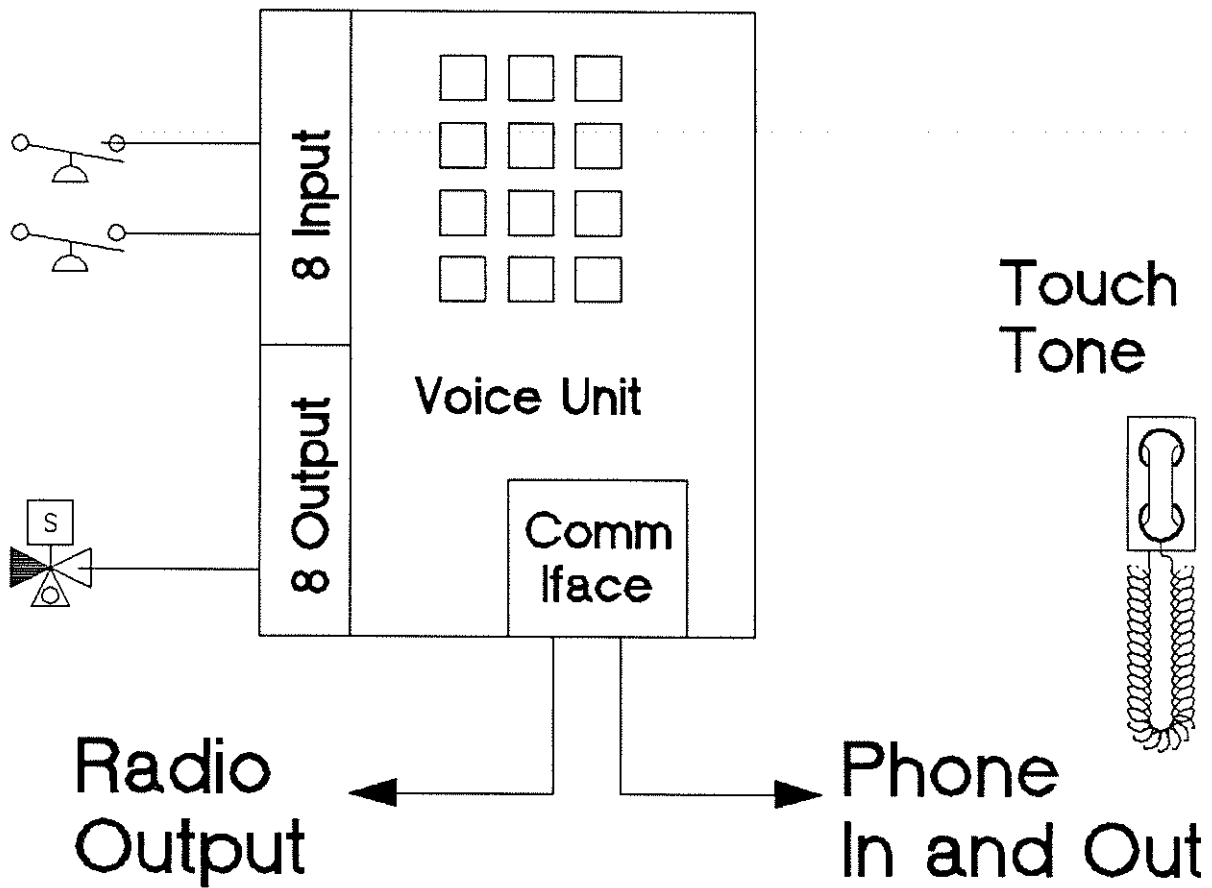

DESIGN FEATURES

Flexible Hardware and Software

Based on Actual Installations

Uses Standard Hardware

DOS Based Software

Features for Offshore and
Remote Locations



HARDWARE FEATURES

Based on Standard Components

Not tied to any Vendor

Allows future enhancements

Tailored to each location

Low power options

High Speed Options



MICRO COMPONENTS

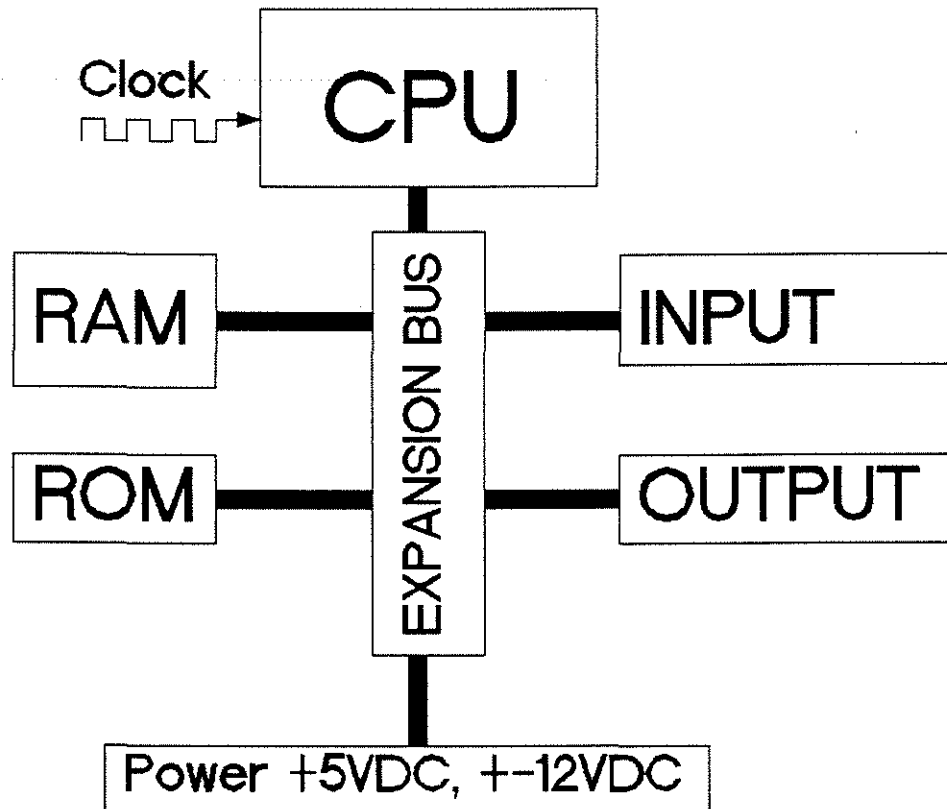

RTU CPU MODULE

PC Compatible Hardware

Low Power Industrial Unit

Supports RAM Disks

No Keyboard or Display
Required for Operation

PC Expansion Bus



DISPLAYS AND KEYBOARDS

Any PC Display Supported

CRT Normally Provided

Portable Unit Available

Color or Mono up to 50 Lines

Separate ANSI Terminal

Standard PC Keyboard

Sealed Units Available

Keyboard NOT Required



RTU DISK DRIVES

Store RTU Programs, Setup Files, and Data Logs

At least One Required

DOS Compatible Formats

Any Floppy Disk Type

Any Hard Disk Type

Solid State (RAM) Disks
have No Moving Parts

Can Mix Types to Meet
Individual Requirements



RTU COMM PORTS

PC Compatible Devices

Normally RS-232 Standard

Up to 4 Ports per RTU

Used for Remote Comm,
Remote I/O, and Extra
CRT Displays

Connect to Modems and
Packet Radio Controllers



MODEM MONITOR

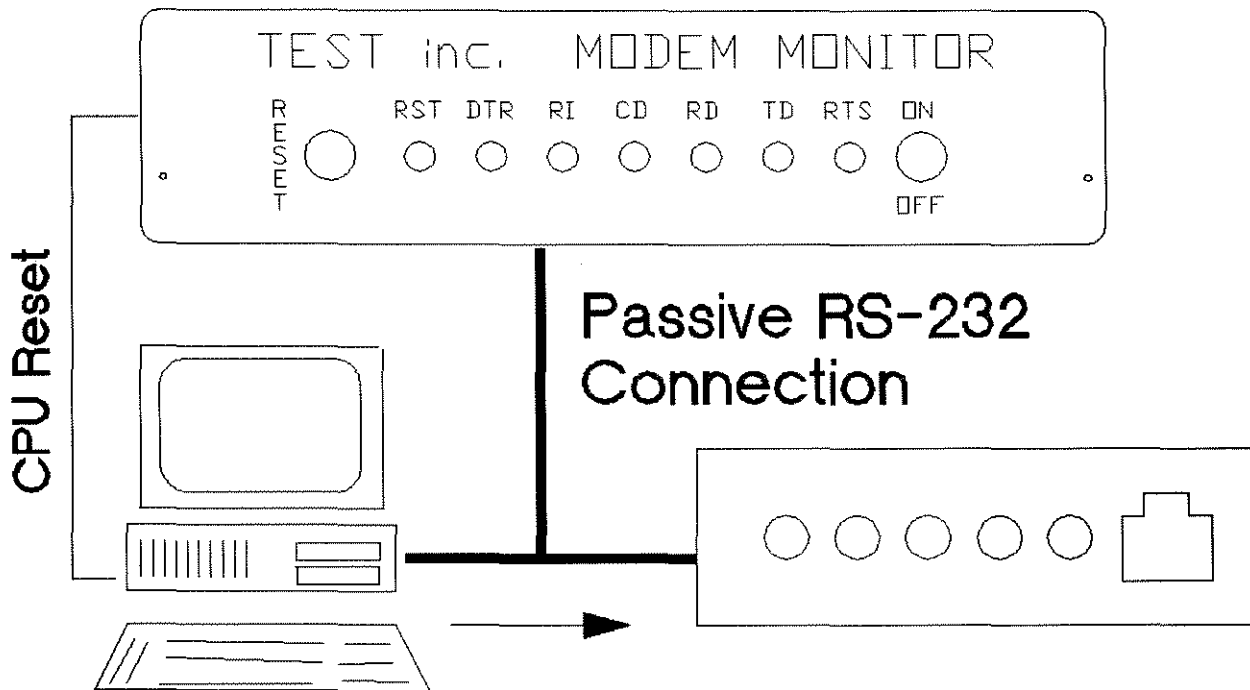

Detects Computer Failure
Counts Modem Rings
Allows Remote Reset
Phone, Radio, LB-100 Versions
Design/Built by TEST



RTU STATUS INPUTS

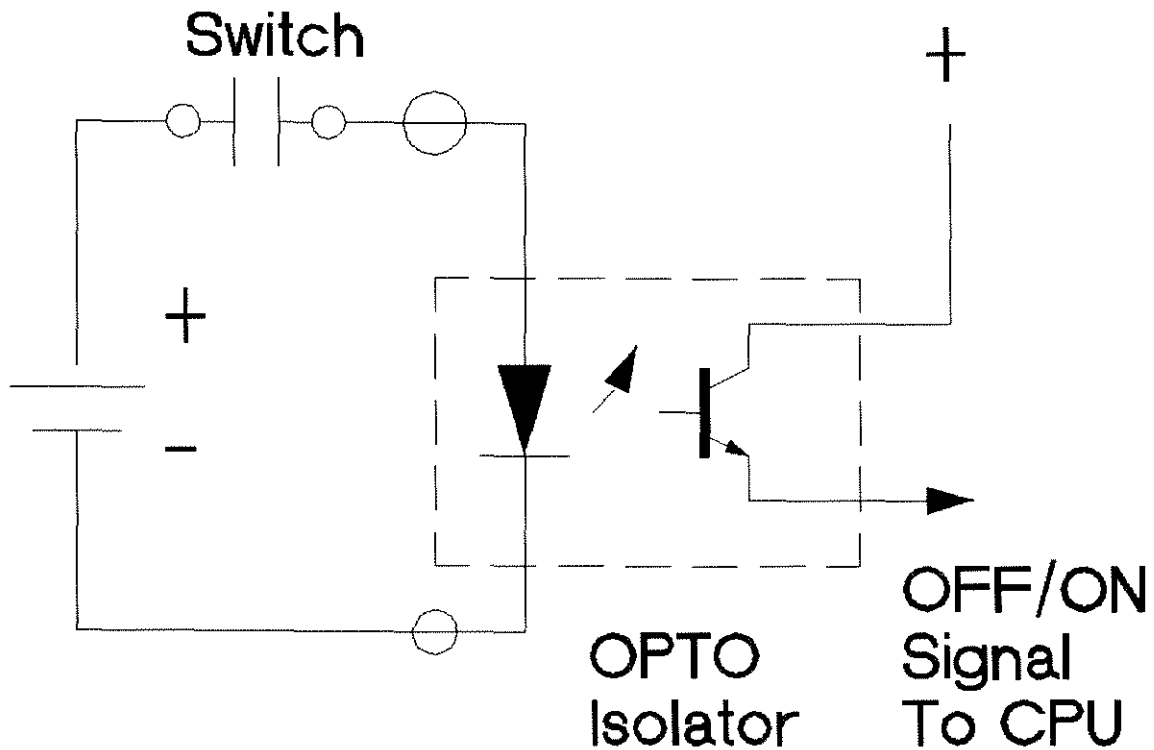

Off-On Status Only
Opto Provides Isolation

RTU STATUS OUTPUTS

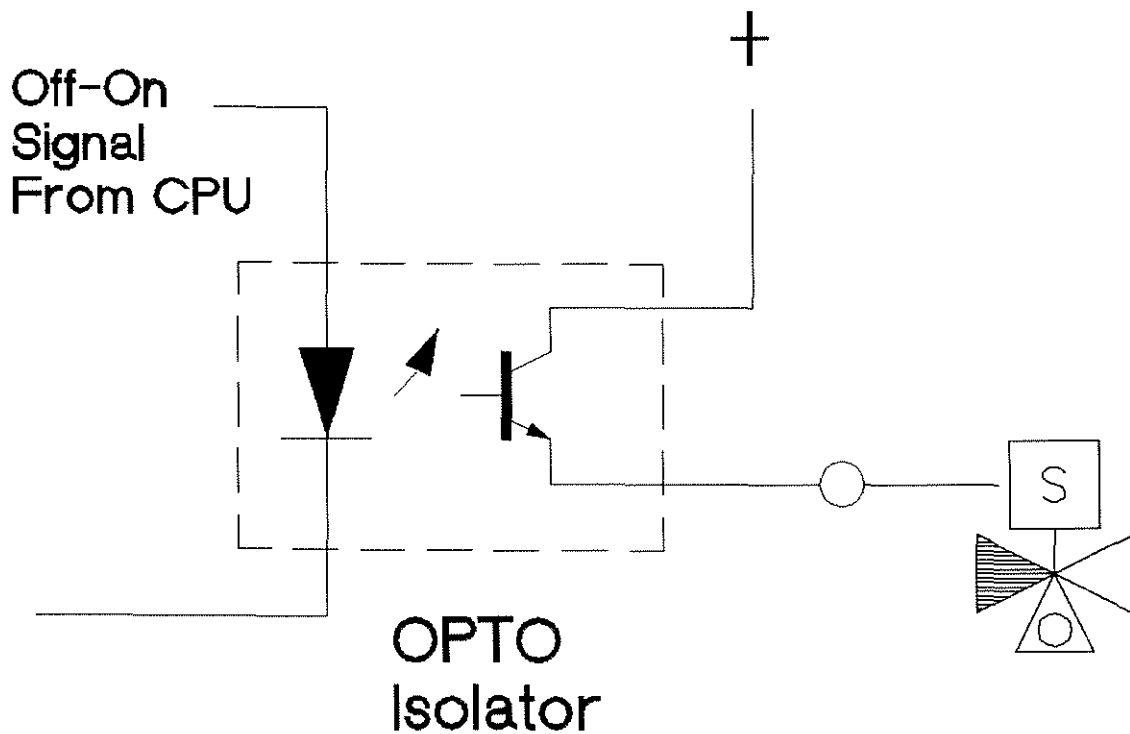

Off-On Control Only
Opto Provides Isolation

ANALOG SIGNALS

Signal varies with process

Often has 20% offset from process zero

Instrumentation signals are linear

Pneumatic and electronic

4-20 ma, 1-5 VDC

3-15 PSI



RTU ANALOG INPUTS

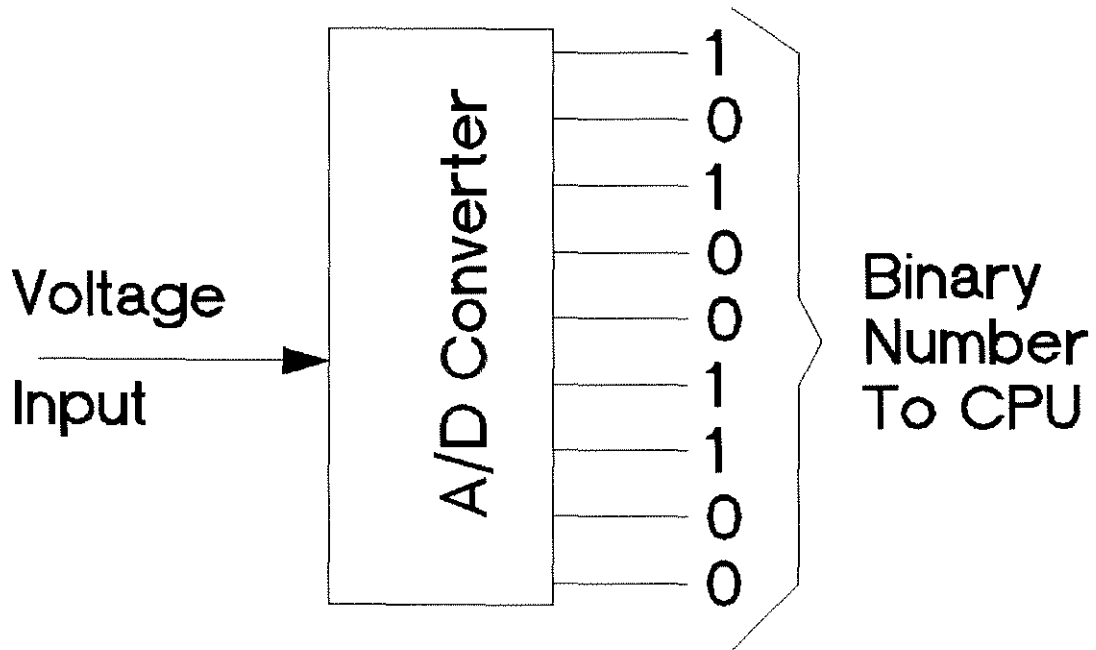

A/D Converter Mates
Voltage to CPU

Binary Number is 0-100%
of Full Voltage Scale

RTU Software Must Convert
Binary to Engr. Units

4-20MA TRANSMITTERS

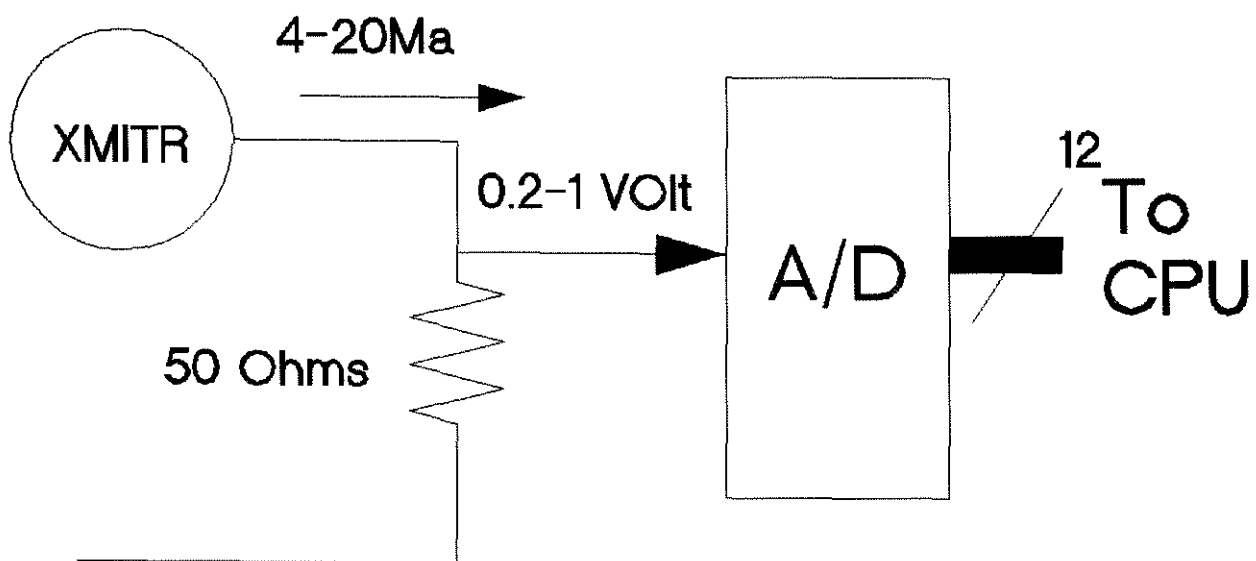

50 Ohm Resistor Gives
1 Volt at 20 Ma Full Scale

RTU Software Converts
A/D Result to Engr. Units

VOLTAGE MEASUREMENTS

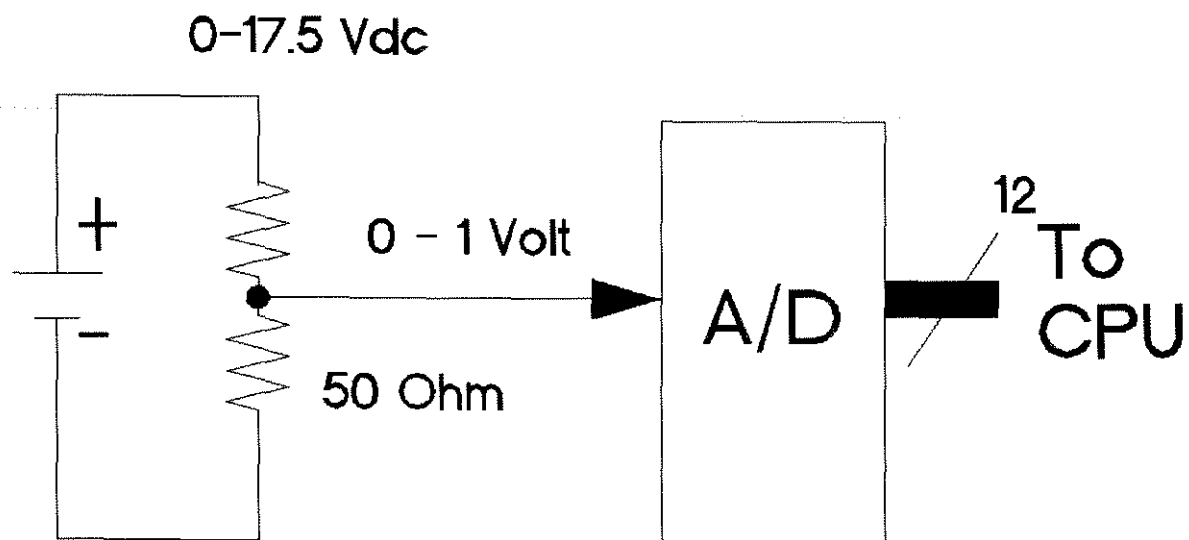

Voltage Divider Gives 1 Volt
When Battery at 17.5 VDC

RTU Software Converts
A/D Result to Engr. Units



PULSE INPUTS

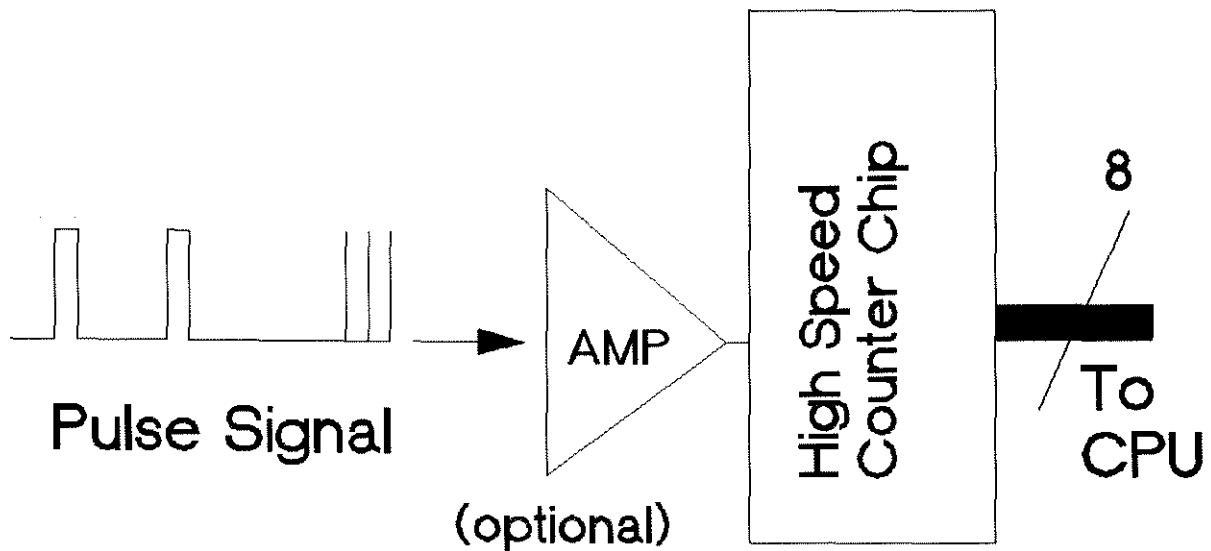

Pulses Represent Events
or Meter Flow

Counter Chip Catches Quick Pulses

RTU Software Calculates Total

PROCESS SWITCHES

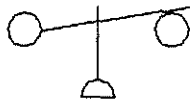

Pressure

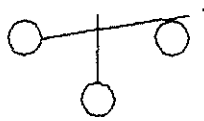

Level

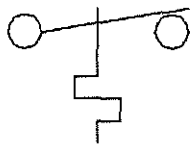

Temperature

Fixed or Adjustable Trip

Fixed or Adjustable Deadband

Various Contact Configs

LEVEL SWITCH

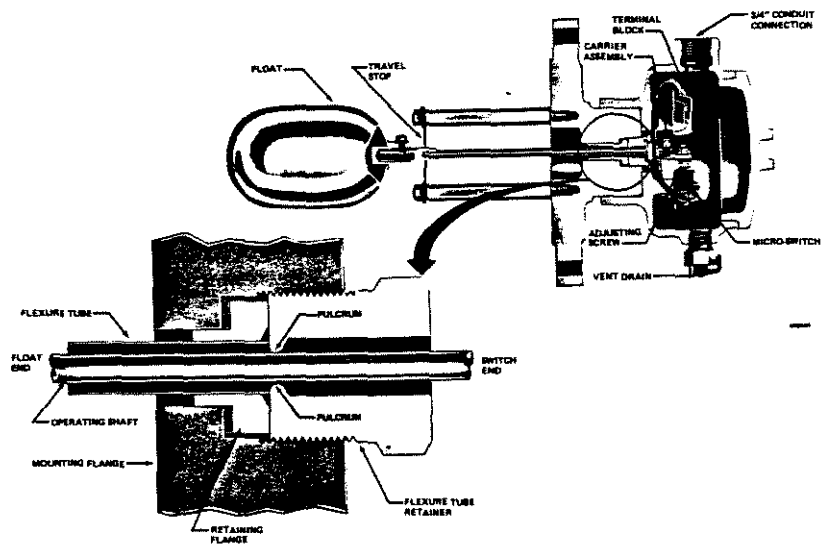
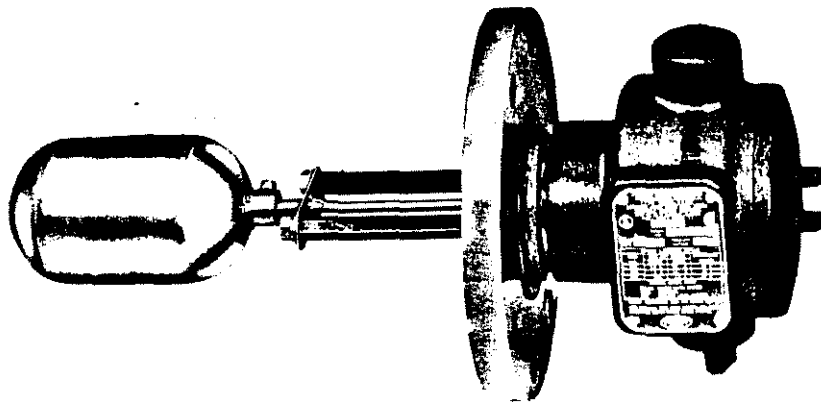

ed003

ANALOG TRANSMITTERS

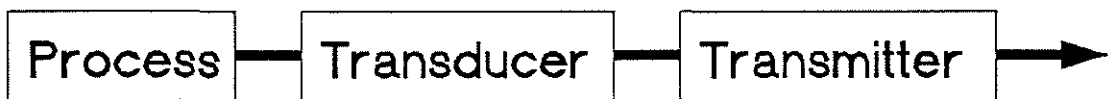

Transducer at Process

Transmitter receives signal from Transducer electronics

Output is Standard Signal

Output is Linear

4-20Ma, 1-5V Most Common

Zero and Span Adjustments



LEVEL SENSING

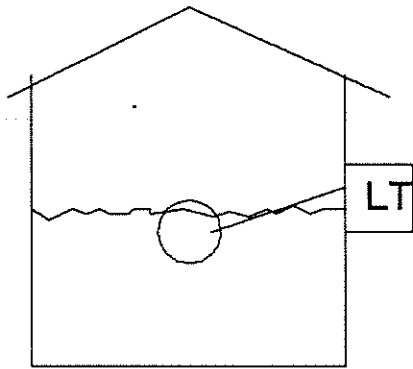

Displacer
Measurement

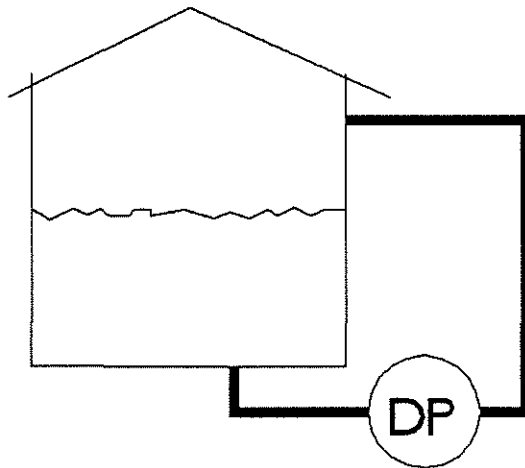

Head
Measurement

PULSE SOURCES

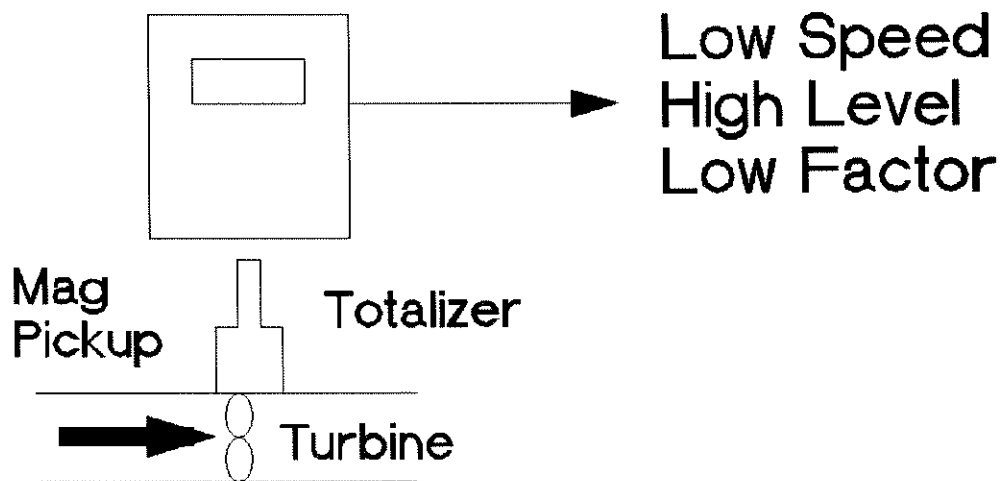
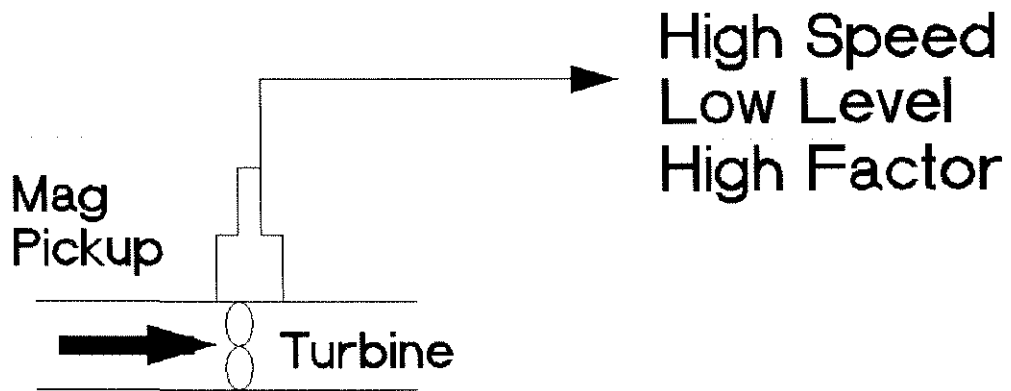

RTU POWER SYSTEM

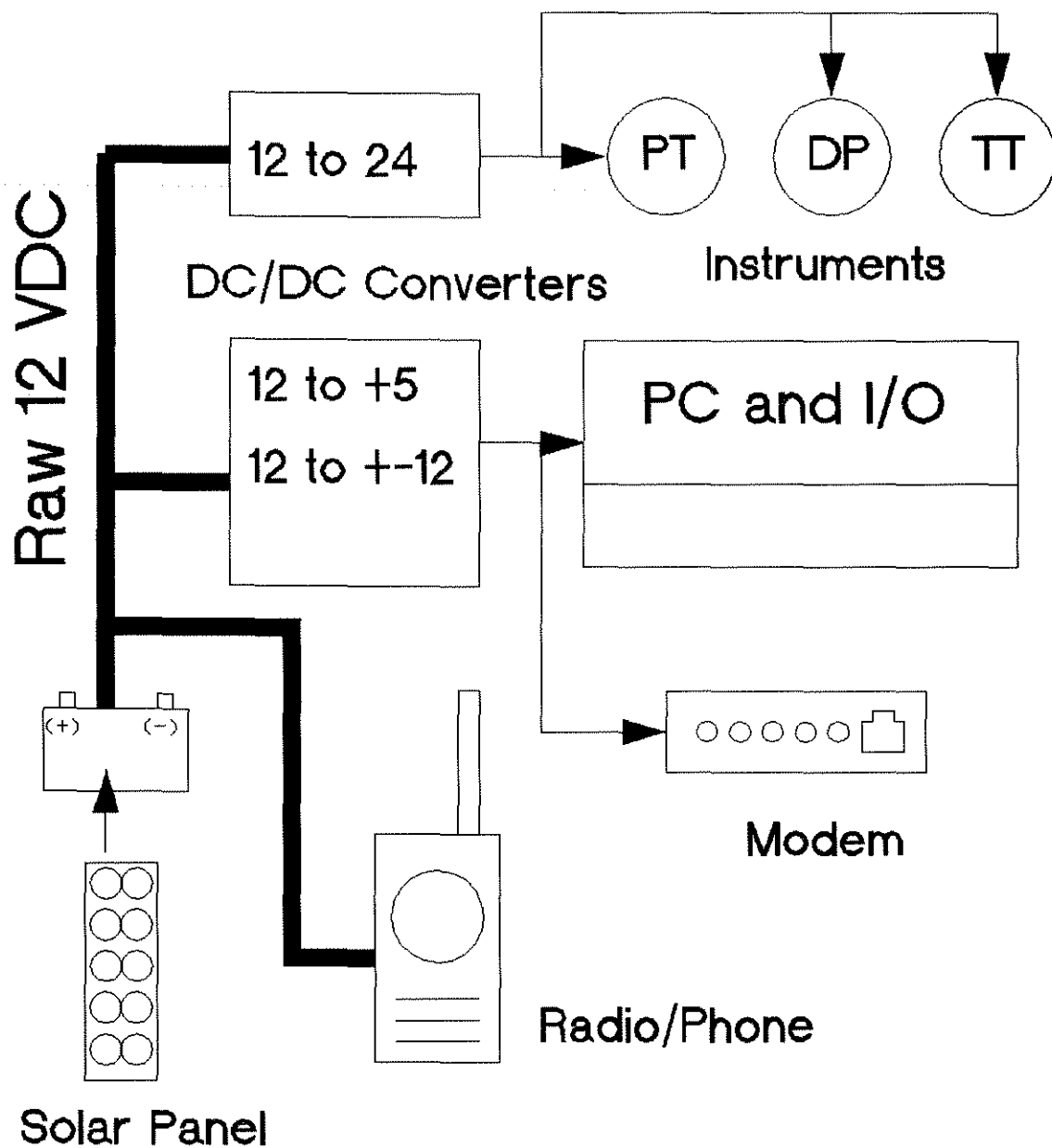

POWER SUPPLIES

Convert primary power

Provide Regulated Voltage

Overcurrent Protection

Over-voltage Protection

Remote Voltage Sensing

Power-Good Logic Signal

Built-in Backup Supply



BASIC SUPPLY

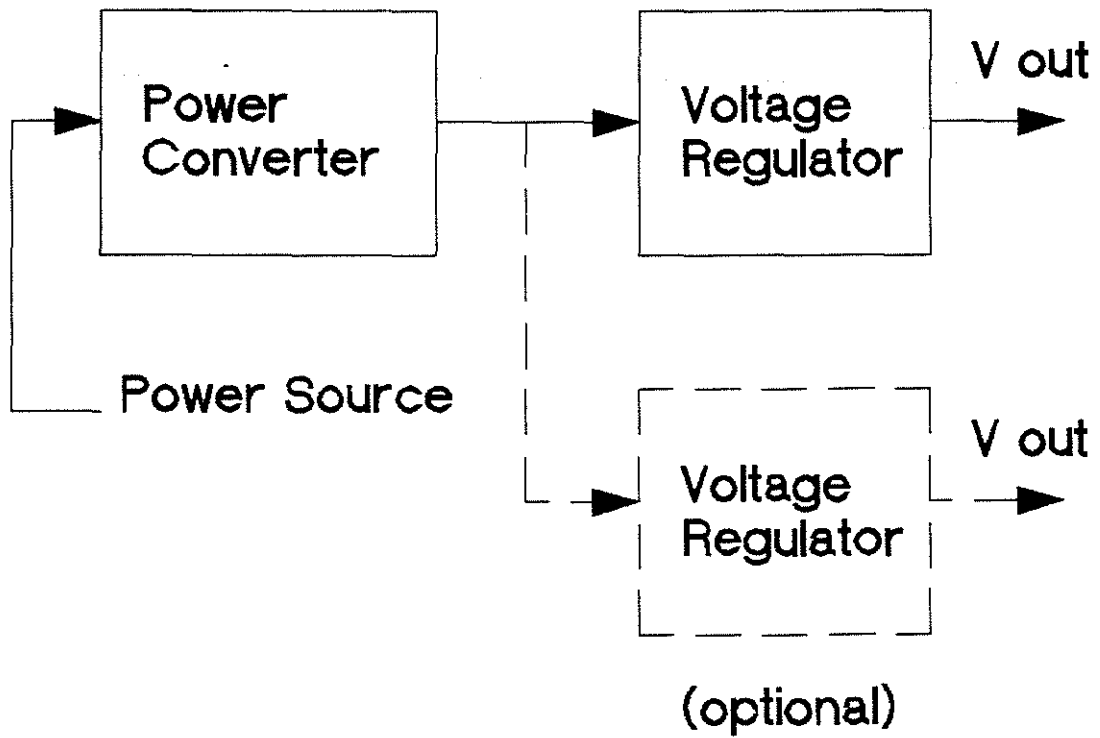

BATTERY BASICS

Electricity from Chemicals

Direct Current Only

Primary Cell - One Time

Secondary Cell - Recharges

Series connection for
Increased Voltage

Parallel Connection for
Increased Current

Cell type determines voltage



CELL TYPES

Lead Acid	2.2 V	Sec
Lead Calcium	2.2 V	Sec
Lead Antimony	2.3 V	Sec
Nickel Cadmium	1.2 V	Sec
Gelatin	2.06 V	Sec
Alkaline	1.5 V	Pri
Carbon Zink	1.5 V	Pri'
Lithium	3.0 V	Pri



CELL CONNECTIONS

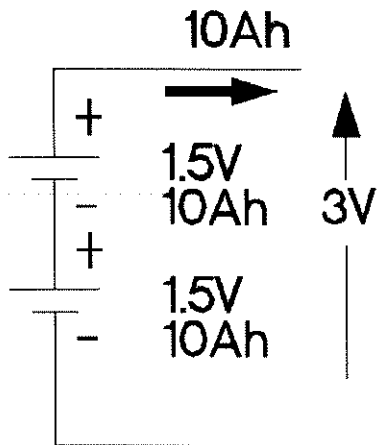

Series for
More Volts

Same Current

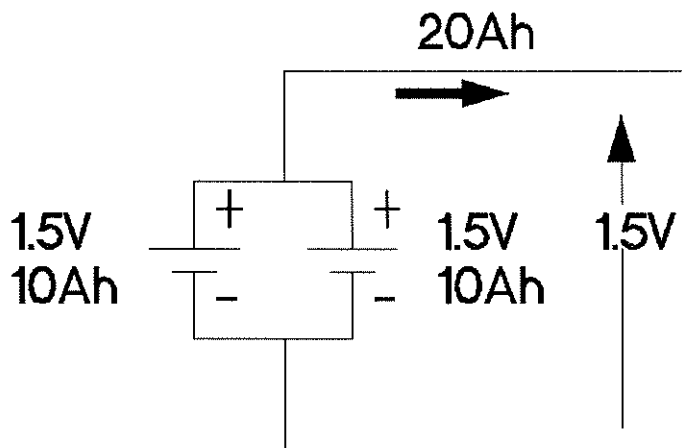

Parallel for
More Current

Same Volts



CHARGING

Secondary Cells Only

Rate depends on Cell type

Trickle - Slow Charge

Equalize - Fast Charge

Most Cell Types Can
be "Floated"

Some Cell Types Can
be Overcharged

Charge State Difficult
to Determine



SOLAR POWER

Low cost due to NASA

Generate low total power

Must be sized for extended
Periods of darkness

Diodes isolate cells

Require large battery reserve

Optimum at latitude +15 deg

Must be kept clean



SOLAR HOOKUP

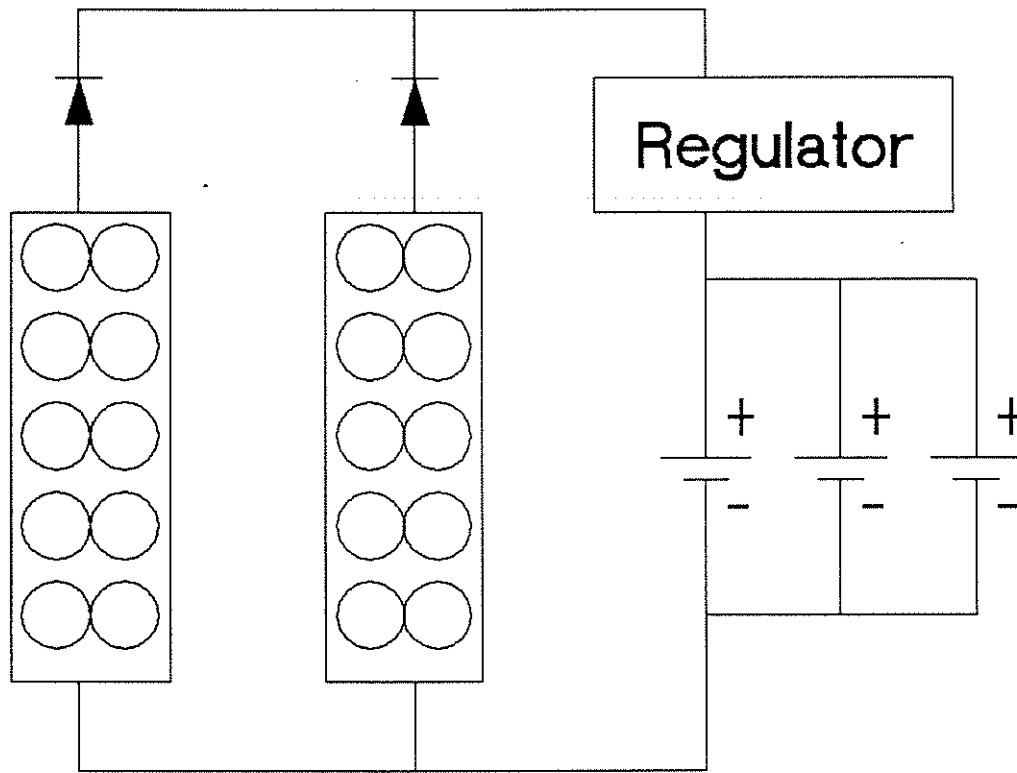

Diodes may be built-in

Regulator May be eliminated

SOLAR ANGLE

Mount at Latitude
Plus 15 Degrees

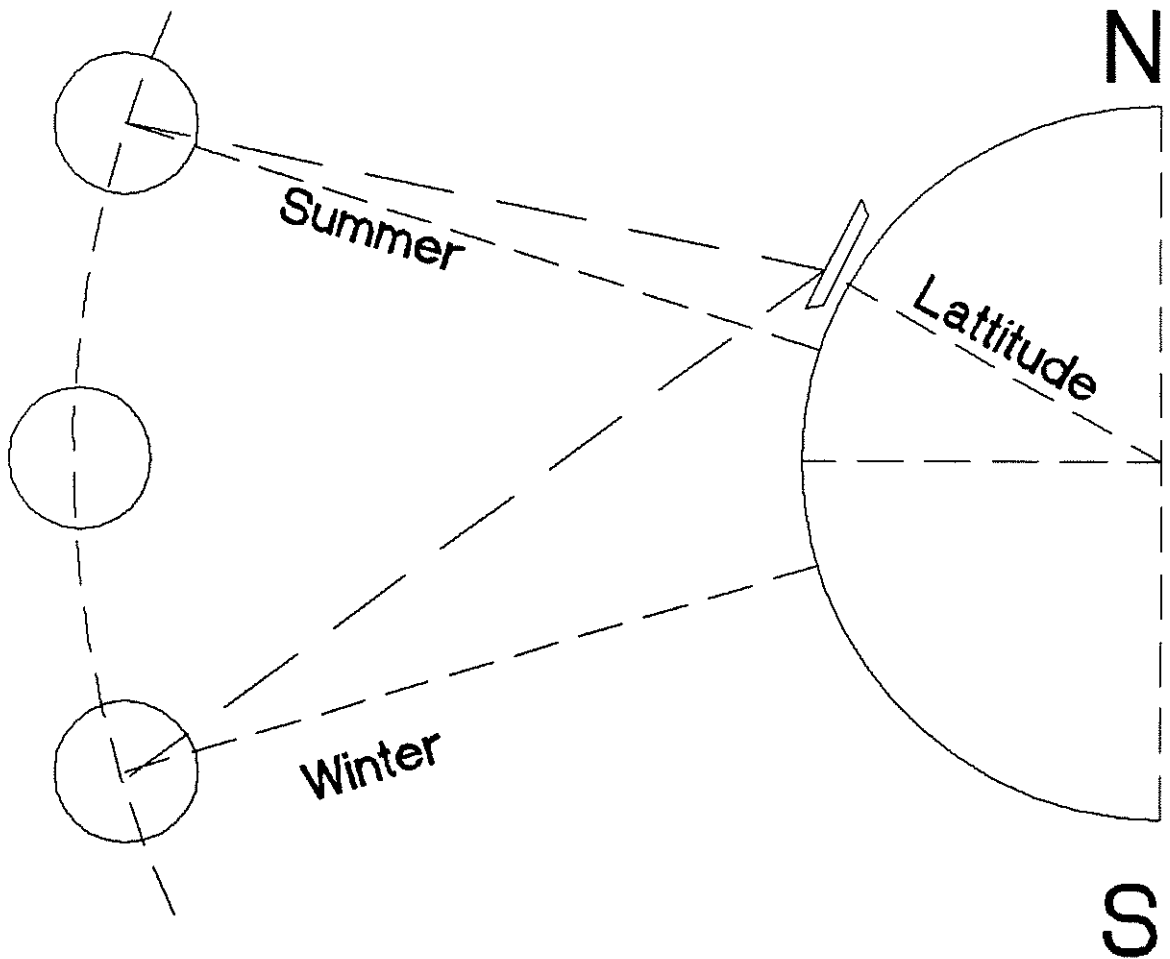

RTU FUNCTIONS

Remote Terminal Unit (RTU)

Provide Remote Information
back to Office (HOST) location

Provide Local Process Info

Limited Control at Remote

Generate Production Info

Relay info Host-to-Host



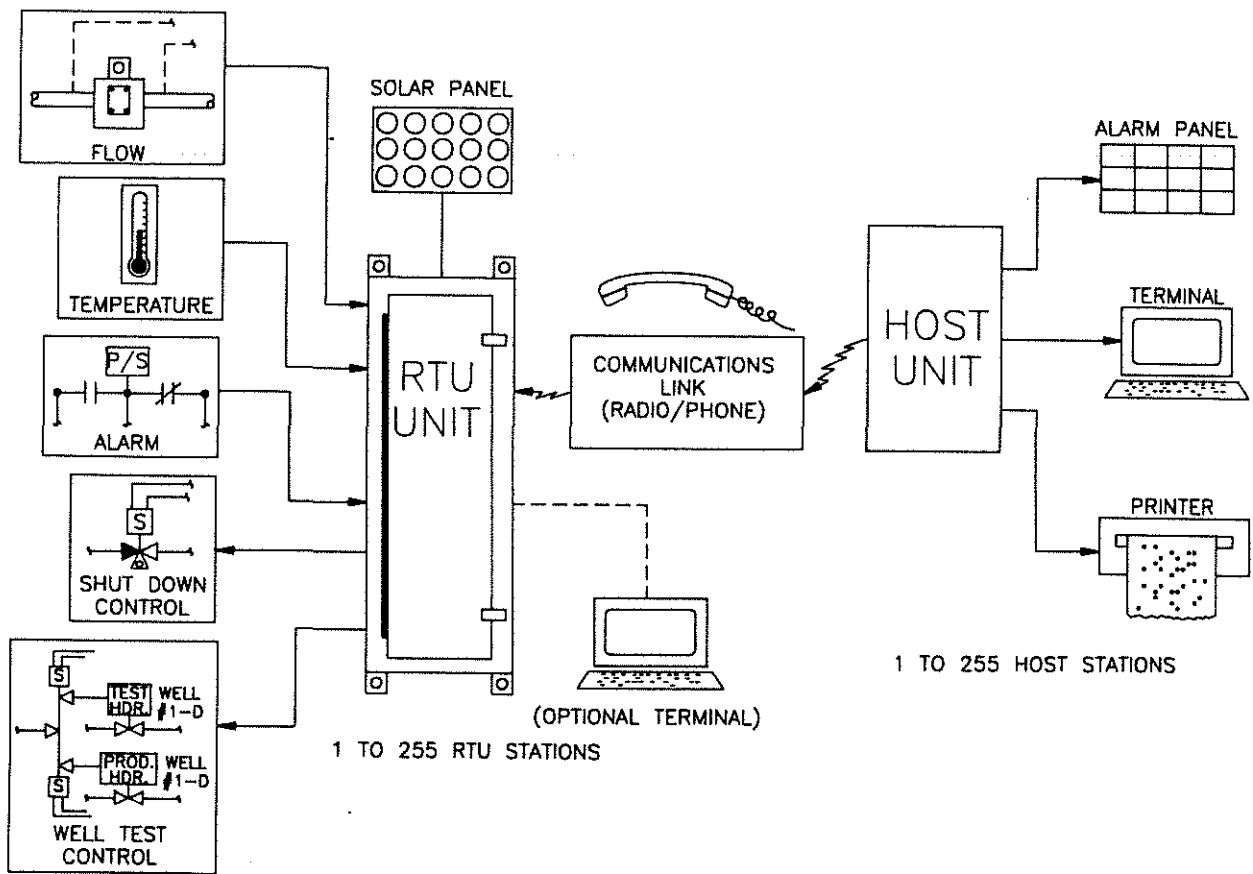

TYPICAL RTU TASKS

Retrieve Status and Analog Data

Alarm on error conditions

Accumulate production info

Remote operation of outputs

Default control on comm loss

May be on-line or dial-up



EQUIPMENT TYPES

DUMB RTU	Basic Signal Conversion and Communications
SMART RTU	Adds Local Intelligence in the Field
RTU/HOST	Local and Remote Points
PC	IBM Personal Computer Compatible Equipment
P.L.C.	Programmable Logic Controller



OVERALL FUNCTIONS

Monitor Input Signals

Determine Out-of-Tolerance
conditions for alarms

Communicate with "HOST" system

Display Information

Generate Status Reports



BIG PICTURE

FIELD LOCATION

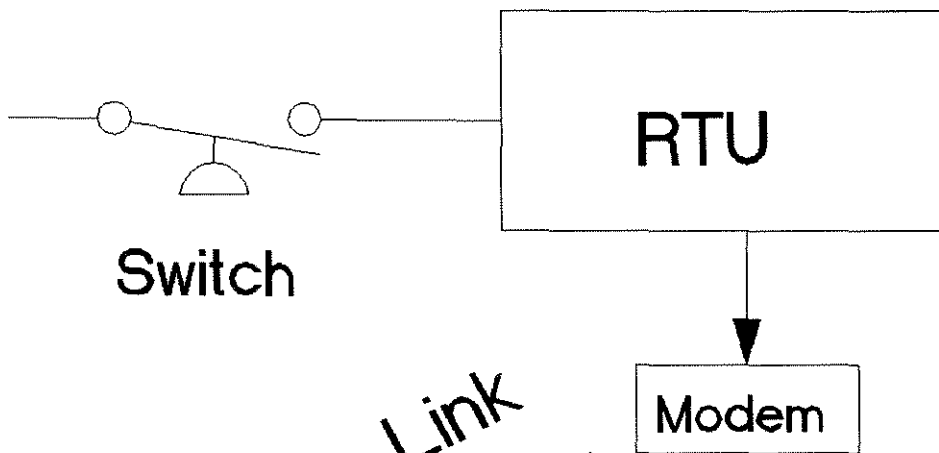

OFFICE

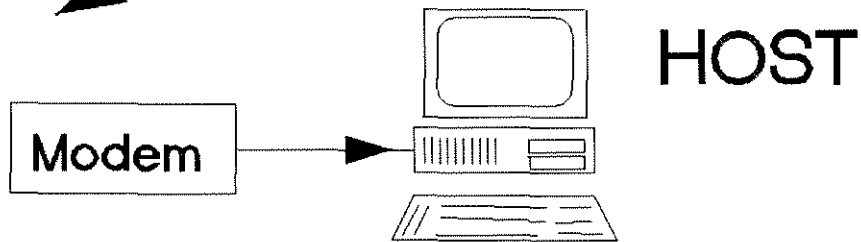

OILFIELD APPLICATIONS

Remote Alarm Reporting

Local Information Display

Remote Data Display/Report

Remote Process Control

Local Control Actions

Production Measurement



OFFSHORE APPLICATIONS

Satellite to Main Platform

Main Platform to Office

Reduce Production Downtime

Extend Production of
Marginal locations

Reduce Transportation Costs

Reduce Unsafe Trips



OFFSHORE PROBLEMS

Unreliable Communications

Difficult Environment

Technical Support

Varying Requirements

Operator Training

Operational Testing

Maintenance



TYPE 24 RTU

Type 2000 Control Board

MicroMint I/O System

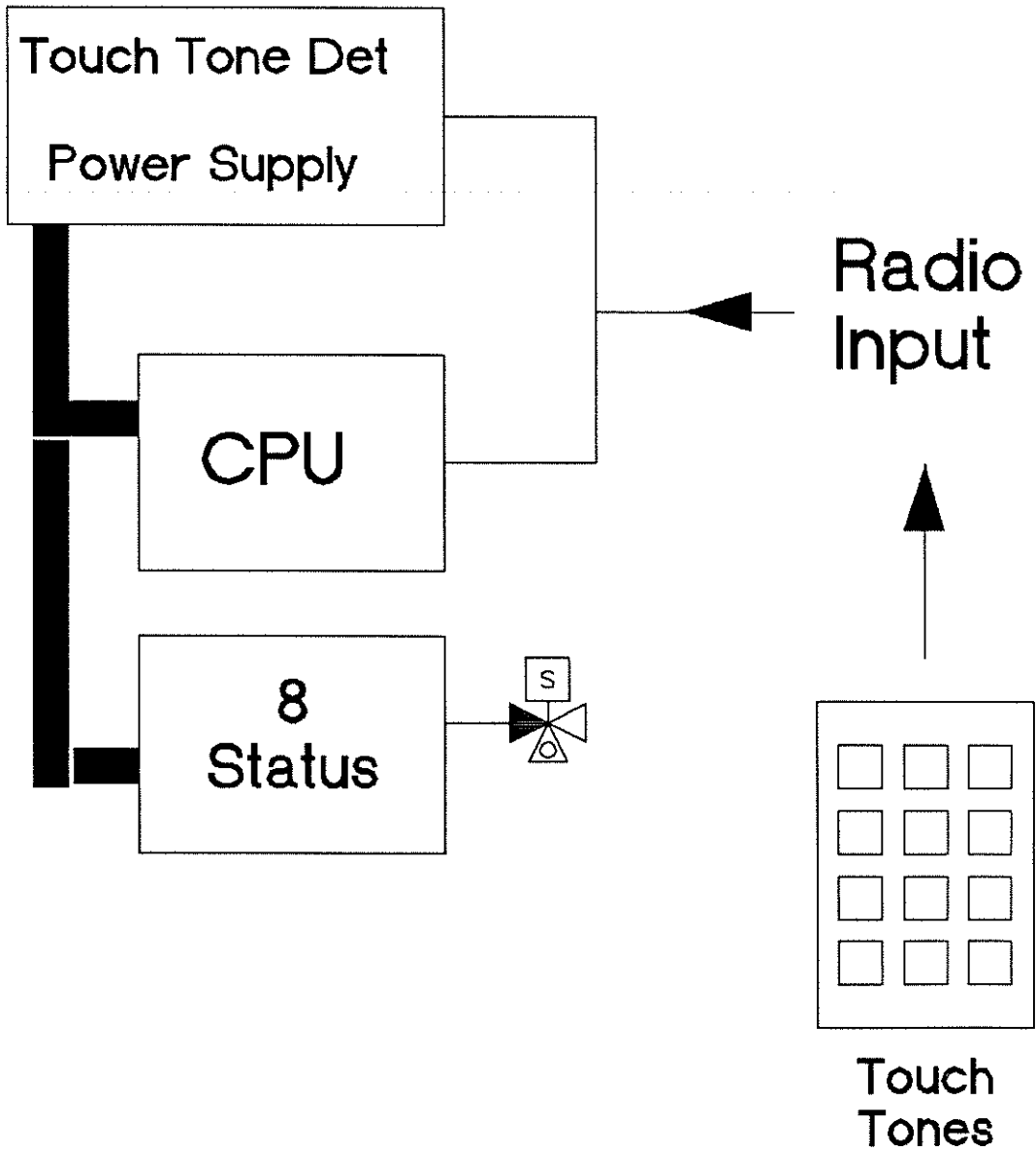

COMPARING MICROS

Processor Data Size

Processor Clock Speed

Instruction Cycle Time

Memory Space

On-board Peripherals



TSP COMMANDS

TSP is both Language and Protocol

Simple Text Command Driven System

Direct Keyboard Entry

Message from Remote Unit

Message from Other Task or Event

Message from Text Command File

TSP COMMAND TYPES

Data and System Configuration:

Config, Change, Hold, SetLow

Data Calculation, Display, Reporting:

AGA3, Galc Display, Menu, Report

Communications Control:

Dial, Hangup, Bye, Link, Hayes, PRC

Alarm Control:

Ack, Reset, Disable, Horn

Data Transfer:

Scan, Data, Block

Command File Control:

Read, If, Endif, Gosub, Sleep, Wait

Diagnostics:

Dump, Stat, Version

System Access:

Logon, Password, *Terminal

DOS File Commands:

Dir, Edit, Exec, Copy

MULTI-DROP COMMUNICATIONS

**Multiple Units Share Common
Communications Path**

Typical in Radio and Hard-Wire Systems

Only One Unit "Talks" At Any Time

Each Station has Unique ID Address

Single Master, Multi-Slave

Multi-Master, Multi-Slave

**Best in Low Traffic, High
Communications Cost Applications**

PC BASED RTU DISADVANTAGES

Very Small Systems Have High Cost

**Typical Applications Reduce Reliability
in Real-Time Control**

**More Complex On-Board Software than
Dedicated RTU or PLC**

**Inadequate Hardware and Software Less
Obvious to Untrained User**

OPEN ARCHITECTURE

Concept of Linking Multi-Vendor Units to Share Internal Data Values

Allows Distribution of Capability Among Otherwise Incompatible Equipment

No Formal Definition or Specification

MODBUS RTU is Common Protocol

FIELDBUS is Future Standard for Instrument Grade Communication

MODBUS Provides Transportation Only

Different Systems "Map" into MODBUS

Registers Hold Low Level Binary Data

PC BASED RTU ADVANTAGES

**Very High Computing Power at Relatively
Low Cost**

Non-Proprietary Designs

**Continuous Development of Industry
Standard Eliminates Obsolescence**

Wide Variety of Components

Common Components Across Systems

Ease of Understanding and Maintenance

OPEN ARCHITECTURE REALITIES

Everything is Not Compatible

Open Architecture is only a tool

**Each Vendor has different restrictions,
features, and interpretations.**

**Required Interfaces can and should be
kept small, typically less than 5% of I/O**

OPEN ARCHITECTURE BENEFITS

Good Solution for Well Designed Sub-Systems and Software

Reduces Overall System Complexity by Isolating Specialized Systems

Reduces System Costs by Widening Choices for each Sub-System

Allows Future Growth Without Unnecessary Initial Expense

OTHER TSP FEATURES

**Data is time stamped when transmitted,
even from Host-to-Host.**

Valid at 12:34:09 06/12/93

**Data related to RTU and Type, Not
physical location in I/O table:**

WC240.A1:A5

Data reference by ID or Tag Name:

WC240.A1 or WC240.WELLPRES

Handles Data and Commands

TYPE 2200 SCADA-Node RTU

Low power, low point-count application

8 Opto-Isolated Status Inputs - Outputs

8 Analog Inputs - 2 Analog Outputs

Talks TSP or Modbus RTU

Any Serial Communications Type

Call-On-Exception Callout Capability

Multiple units can share comm modems

Slave I/O Device for larger TEST RTU

MODBUS RTU PROTOCOL

Commonly used for Open Architecture

**Roots in Direct Connect (wired) PLC
Technology**

No Formal Technical Specification

Binary data transfer only - Bits, Bytes

No RTU or SCADA Level Components

Single Smart Master to Multiple RTU's

Multi-Drop wire or radio only

No Call on Exception Support

TEST SCADA PROTOCOL

**TSP Developed for Oilfield SCADA,
useful for any SCADA**

Simple, Reliable, Text Based Design

**SCADA Data Types - Status, Analog,
Timer, Counter, Meter, etc.**

**Full Error Checking, Sequencing,
Routing, and ACK for every message.**

**Optimized Communications with Multiple
Data Types per Scan.**

**Protocol is also TSP Programming
Language**

Very Flexible Communications

Published Formal Specification by TEST

**SCADAWARE Provides "Map" into other
PLC and RTU Protocols**

AGENDA SYSTEM

Processes RTU Commands at Specified Time of Day

Can send command to any task

Can be dynamically changed

Normally starts CMD file

Used for daily Logoffs



RTU DIAGNOSTICS

Check Basic RTU operation

Verify Input Operation

Verify Local values for inputs

RTU processes Raw and
Converted Values

Check basic Comm Link

Monitor Data at various points



DIAGNOSTICS

Built-In to RTU and HOST

See Problems Inside System

Task Monitoring

Communications Status

Message Monitoring

Data Transfer "Watch"

Manual Simulations



DATA TRANSFERS

Initiate Callout to Other Unit

After Connect Send Data

Clear Alarms at RTU End

Generate Alarms at HOST End

Disconnect Comm Link

Process Other Links



SCAN/DATA COMMANDS

SCAN - Ask System for Point Data

DATA - Holds System Point Info

SCAN Cmd Generates DATA Line

RTU Processes SCAN, Sends
DATA Line to HOST

DATA Lines can be Stored

RTU

SCAN A1:A4 E

HOST

DATA VR256E.A1:A4 E 12 34 56 78



SCAN/DATA OPTIONS

Engineering Units

Raw Units

Channel Time and Date

Update Time and Date

AGA3 Error Numbers

Multiple SCANS per Line

Automatic Time Stamp



RTU DOWNLOAD FILE

Set Online ON

SCAN a1:a8 E m1:m2 E

SCAN s1:s16 R o1:o8 R

SCAN c1:c4 E q1:q2 E

SCAN V1:v8 E[®]

Set online off

BYE



CALC COMMAND

Set Channel Values

Uses Expression Evaluator

Channel Reference by TAG
or Point ID, or Variable

Assumes Current RTU

Functions like Sin, Cos, <>

Command Line Parameters Can
be used in Files

Calc o1 = On

Calc o1:o4 = off

Calc TOTAL = tot1 + tot2

Calc DAYTOT = C1 + DAYTOT



CONFIG COMMAND

Setup for Channels and Links

Separate Screen for each
Channel Type

Easily Move Among All
Channels of Same Type for
Each RTU

Screen Cursor Stays on
Same Field after Move

Setups only in Memory
Until SAVE Command



DUMP/STATUS COMMAND

Display System Information
not Related to Channel Values

STAT provides Real-Time Displays

DUMP Provides Param Listing

STAT - Tasks, Comm, Links, Files

DUMP - RTU, TASK, I/O



RTU COMMANDS

Processed by RTU, Utility, and Calculator Tasks only

Consist of Command and some number of keywords or parameters

Humans use Plain Text format

Computers use special error correcting format

Local CRT has special commands



COMMAND FILES

Store prepared command scripts

DOS files or RTU Library

Parameters for Multiple Use
of Single File

Started by hand, timer,
agenda, or abnormal.

Execution controlled by COMM
LINK status.

Allow programmed Operator
Input and Custom Displays



TYPICAL CMD FILE

```
Select SMI7  
Dial  
Wait connect 45  
Set Online On  
MSG RTU $R is Online  
Gosub Pulse_timer  
Msg Shut In command Sent  
Sleep 45  
Block READ DOWNLOAD
```



TEXT EDITOR

Allows on-line editing of RTU files and Libraries.

Can edit any ASCII DOS File.

Has search, replace, block copy and move type functions.

Pop-Up Directory Display

On-line Help System (1991)



FUNCTION KEYS

Quick access to frequent cmds.

- F1 - Silence Local Horn
- F2 - ACK New Alarms on Display
- F3 - RESET Old Alarms on Display
- F4 - Print Report for RTU
- F5 - Poll Current RTU
- F7 - Display RTU Data
- SHFT-F7 - Display First Out Alarm
- F9 - Start Pop-Up Menu
- F10 - RTU Select Menu



DATA DISPLAYS

Shows Current RTU data

Indicates Alarm Status

Easily flip among channel types
and various RTU locations.

Easily Started with F7

Remote Systems indicate the
last Update Time and Date



```

RTU 1 GA343A - WACKER OIL GA343A | 19:04:21
STATUS INPUT CHANNELS|- R E M O T E P O I N T S - Updated |11/30/90 19:04:15
CH TAG CHANNEL NAME LATCHED-STATUS ALARM
1 LSH400 Skimmer In Service
2 LSH450 Cond. Surge Tank In Service
3 LSH800 Sump Tank In Service
4 SSV-343 SSV Status In Service
5 SSCV343 SCSSV Status In Service
6 S6 Channel S6 Off
7 S7 Channel S7 Off
8 S8 Channel S8 Off

```

[S]tat [O]ut [A]log [M]eter [C]ntrs [F]rq [T]imer [Q]total [V]alue --+ ESC

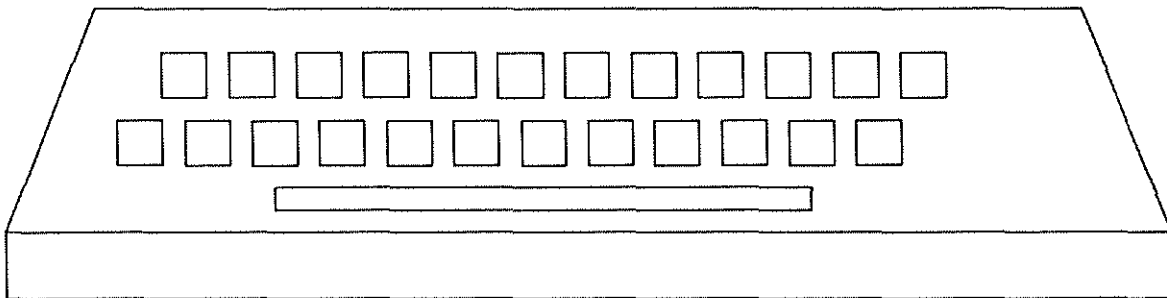

```

RTU 1  GA343A      - WACKER OIL GA343A      | 19:05:07
ANALOG INPUT CHANNELS|- R E M O T E  P O I N T S - Updated |11/30/90 19:04:15
CH  TAG  ANALOG INPUT NAME  VALUE  CTL  ALARM
1  NAVAID  Nav Aid Light Power  0.00 Volts
2  FOGHORN  For Horn Power  0.00 Volts
3  RTUVOLT  RTU Supply Voltage  0.00 Volts
4  PT300  H.P. Separator Press  0.00 Psig
5  PT400  Skimmer Pressure  0.00 Psig
6  PT700  Fuel Gas Pressure  0.00 Psig
7  PT901  Sales #1 Static Pres  0.00 Psig
8  DPT901  Sales #1 Diff Press  0.00 Inches
9  TT901  Sales #1 Temperature  0.00 DEG F
10 PT902  Sales #2 Static Pres  0.00 Psig
11 DPT902  Sales #2 Diff Press  0.00 Inches
12 TT902  Sales #2 Temperature  0.00 Deg-F
13 PT950  Pipeline Pressure  0.00 Psig
14 PT200  Test Sep Pressure  0.00 Psig
15 DPT200  Test Sep Diff Press  0.00 Inches
16 A16  Channel A16  0.00 Units

```

[S]tat [O]ut [A]log [M]eter [C]ntrs [F]rq [T]imer [Q]total [V]alue --+ ESC

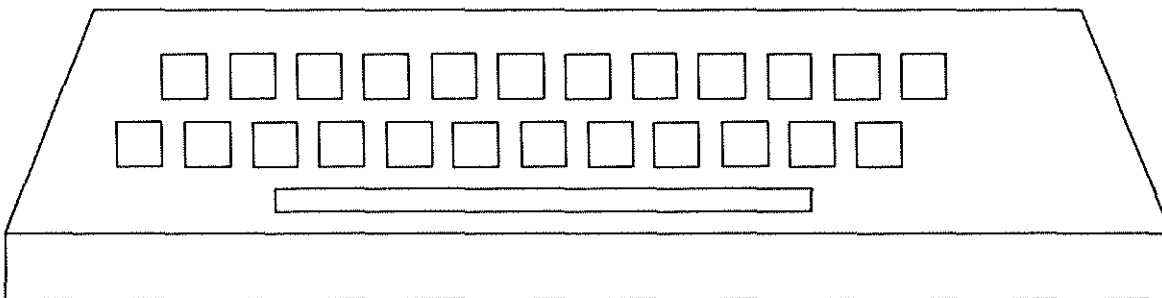

```

RTU 1 GA343A - WACKER OIL GA343A | 19:05:39
AGA-3 METER CHANNELS|- R E M O T E P O I N T S - Updated |11/30/90 19:04:15
CH TAG AGA-3 METER NAME RATE PLATE CTL ERR ALM
1 M1 Gas Sales 1 0.00 MCF/Hr 8.000 0
2 M2 Gas Sales 2 0.00 MCF/Hr 3.500 0
3 M3 TEST METER 0.00 MCF/Hr 1.250 0

```

[S]tat [O]ut [A]log [M]eter [C]ntrs [F]rq [T]imer [Q]total [V]alue +- ESC

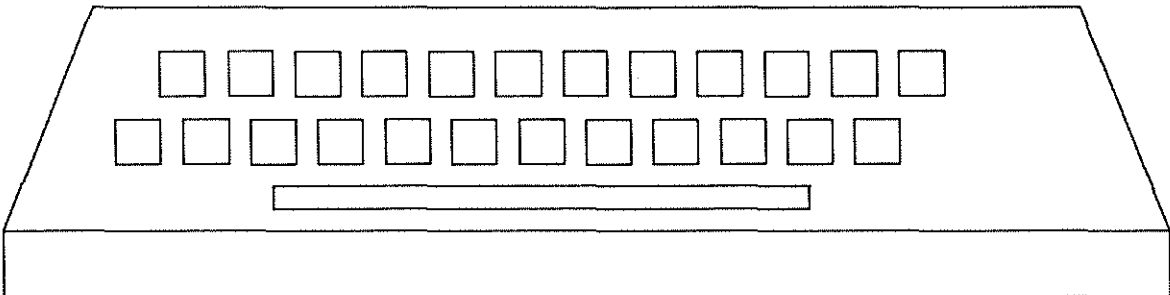

```

RTU 1 GA343A - WACKER OIL GA343A | 19:08:32
VALUE CHANNELS | - R E M O T E P O I N T S - Updated | 11/30/90 19:04:15
CH TAG VALUE CHAN NAME V A L U E ALM
1 PLATE1 Gas Sales #1 Plate 8.00 Inches
2 PLATE2 Gas Sales #2 Plate 3.50 Inches
3 PLATE3 Test Meter Plate 1.25 Inches
4 SG Gas Spec Grav 0.58 SG
5 MCO2 GAS % MCO2 0.55 Pct
6 MN2 Gas % MN2 0.20 Pct
7 YG1 Yesterday Sales #1 0.00 MMCF
8 YG2 Yesterday Sales #2 0.00 MMCF
9 YGT Yesterday Test Meter 0.00 MMCF
10 V10 Channel V10 0.00 Units
11 V11 Channel V11 0.00 Units
12 V12 Channel V12 0.00 Units
13 V13 Channel V13 0.00 Units
14 V14 Channel V14 0.00 Units
15 V15 Channel V15 0.00 Units
16 TESTEMP Test SEP Meter Temp 70.00 Deg-F

```

[S]tat [O]ut [A]log [M]eter [C]ntrs [F]rq [T]imer [Q]total [V]alue -- ESC

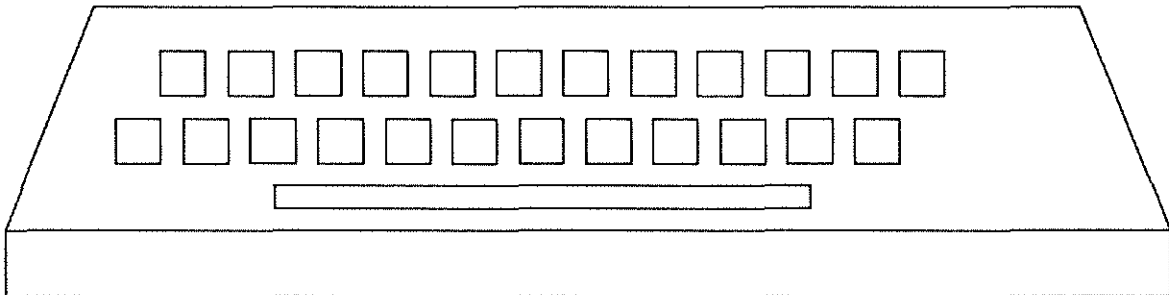

REPORT COMMAND

Produces Standard Report for
Current or Any RTU

FOR Option Specifies RTU

TO Option Specifies Destination

Printer Must be Enabled to
Get a Printout

Destinaton May be File

Report

Report for VR256E

Report For SMI7 to SMI7.REP



```

----- STATUS INPUT CHANNELS -----
CH TAG CHANNEL NAME LATCHED-STATUS ALARM
1 LSH400 Skimmer In Service
2 LSH450 Cond. Surge Tank In Service
3 LSH800 Sump Tank In Service
4 SSV-343 SSV Status In Service
5 SSCV343 SSCSV Status In Service
----- ANALOG INPUT CHANNELS -----
CH TAG ANALOG INPUT NAME VALUE CTL ALARM
1 NAVAID Nav Aid Light Power 0.00 Volts New
2 FOGHORN For Horn Power 0.00 Volts New
3 RTUVOLT RTU Supply Voltage 0.00 Volts New
4 PT300 H.P. Separator Press 0.00 Psig
5 PT400 Skimmer Pressure 0.00 Psig
6 PT700 Fuel Gas Pressure 0.00 Psig New
7 PT901 Sales #1 Static Pres 0.00 Psig
8 DPT901 Sales #1 Diff Press 0.00 Inches
9 TT901 Sales #1 Temperature 0.00 DEG F
10 PT902 Sales #2 Static Pres 0.00 Psig
11 DPT902 Sales #2 Diff Press 0.00 Inches
12 TT902 Sales #2 Temperature 0.00 Deg-F
13 PT950 Pipeline Pressure 0.00 Psig
14 PT200 Test Sep Pressure 0.00 Psig
15 DPT200 Test Sep Diff Press 0.00 Inches
----- AGA-3 METER CHANNELS -----
CH TAG AGA-3 METER NAME RATE PLATE CTL ERR ALM
1 M1 Gas Sales 1 0.00 MCF/Hr 8.000 0
2 M2 Gas Sales 2 0.00 MCF/Hr 3.500 0
3 M3 TEST METER 0.00 MCF/Hr 1.250 0
----- TOTALIZER CHANNELS -----
CH TAG TOTALIZER NAME TOTAL CURRENT --STARTED-- ALM
1 Q1 Sales Gas Meter #1 0.00 MMCF 0.00 19:21 11/30
2 Q2 Sales Gas Meter #2 0.00 MMCF 0.00 19:21 11/30
3 Q3 Test Sep. Meter 0.00 MMCF 0.00 19:21 11/30
----- COUNTER INPUT CHANNELS -----
CH TAG COUNTER NAME ACCUMULATED VALUE CONTROL --STARTED-- ALM
1 FQI401 Produced Water 0.00 Bbls 19:21 11/30
2 FQI470 Cond. Meter No. 1 0.00 Bbls 19:21 11/30
3 FQI471 Cond. Meter No. 2 0.00 Bbls 19:21 11/30
5 FQI200 Test Sep. Cond. 0.00 Bbls 19:21 11/30
6 FQI201 Test Sep Water 0.00 Bbls 19:21 11/30
----- FREQUENCY CHANNELS -----
CH NAME CURRENT VALUE CTRL UPDATE ALM
1 F1 Sales Rate #1 0.00 Cps
2 F2 Sales Rate #2 0.00 Cps
3 F3 Oil Sales Rate 0.00 Cps
4 F4 Water Rate 0.00 Cps
----- VALUE CHANNELS -----
CH TAG VALUE CHAN NAME VALUE ALM
1 PLATE1 Gas Sales #1 Plate 8.00 Inches
2 PLATE2 Gas Sales #2 Plate 3.50 Inches
3 PLATE3 Test Meter Plate 1.25 Inches
4 SG Gas Spec Grav 0.58 SG
5 MCO2 GAS % MCO2 0.55 Pct
6 MN2 Gas % MN2 0.20 Pct
7 YG1 Yesterday Sales #1 0.00 MMCF
8 YG2 Yesterday Sales #2 0.00 MMCF
9 YGT Yesterday Test Meter 0.00 MMCF

```



POP-UP MENUS

Allow 1 button automation

Easily configured in field

Unlimited number of menus

Menu "gosub" supported

Mouse selection supported

DOS files or Library Proc



PLATESET.RTU
 QUIT.RTU
 RELAY.RTU
 S8.RTU
 START0.RTU
 START1.RTU
 T1.RTU
 T8.RTU
 TEST1.RTU
 TEST2.RTU
 TEST3.RTU
 TEST4.RTU
 TEST5.RTU
 TOTFLOW.RTU
 UPD_RTU.RTU
 WC433A.RTU
 WC457B.RTU
 X.RTU
 XNAY.RTU
 XX.RTU
 Y.RTU
 Disk D has 6,805,504 Bytes free out of 33,431,552
 DEMO! GA343A 0> ♥**CANCEL**
 MENU

ART's COMPUTER TEST MENU

TEST
 DISPLAY ANALOG POINTS
 Test Task 1
 POLL THE CURRENT RTU
 SHOW DEMO SCREEN
 PRINT DEMO SCREEN
 LOAD SECOND MENU
 EXIT MENU MODE
 EXIT THE PROGRAM

TEST4.RTU	180	2/07/90	18:36:06
TEST5.RTU	70	2/08/90	10:38:30
TOTFLOW.RTU	598	3/01/90	19:50:00
UPD_RTU.RTU	130	9/13/89	18:54:26
WC433A.RTU	2,127	7/26/89	12:29:46
WC457B.RTU	2,153	7/26/89	12:20:52
X.RTU	72	7/17/90	14:03:50
XNAY.RTU	35	6/01/90	16:02:44
XX.RTU	175	9/07/90	16:43:04
Y.RTU	62	6/04/90	14:46:24

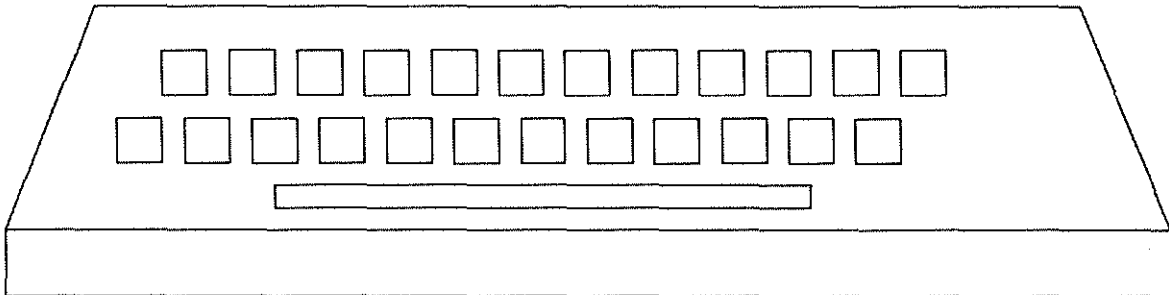

BLOCK COMMAND

Sends Command to Other Unit

Verifies that Line Received

Automatic Retry if Fail

Verification May be Reply
from Other Unit to Save
Transmission Time

Typical Use is to Pulse
Output Timer at RTU

BLOCK Calc T1 = 15



EXEC/SHELL COMMAND

Allows Temporary Access to
DOS and Small DOS Programs

Holds up Some SCADA Program
Processes and Functions

Normally used for Clock,
Copy, other Quick Accesses

Bending Many DOS Restrictions

EXEC ATCLOCK
SHELL COPY *.rtu B:



FORCE COMMAND

Sends Commands to Other Tasks

Used from Console, Menus,
and Command Files

Lets One Task Control Another

Parameters are Processed by
Sending RTU Task

Force Util Read Daily
Force 1 Sele \$R
Force 1 force 0 Time



WATCH COMMAND

Allows Console Task to Monitor
Commands and Messages for
Other RTU Type Tasks

Works on Comm, Message, and
File Commands to the Task

Additional Task Status Info

More than One Task Can
be Monitored

Watch 1
Watch Util
Watch Off



RTU 1 GA343A - WACKER OIL GA343A | 19:04:39
STATUS OUTPUT CHANNELS | - R E M O T E P O I N T S - Updated | 11/30/90 19:04:15
CH TAG OUTPUT NAME CURRENT STATUS ALARM
1 01-343 SSV Shutdown Not Active
2 02-343 SCSSV Shutdown Not Active
3 03-343 SCSSV Shutdown Not Active
4 04-343 SCSSV Reset Not Active

[S]tat [O]ut [A]log [M]eter [C]ntrs [F]rq [T]imer [Q]total [V]alue -- ESC

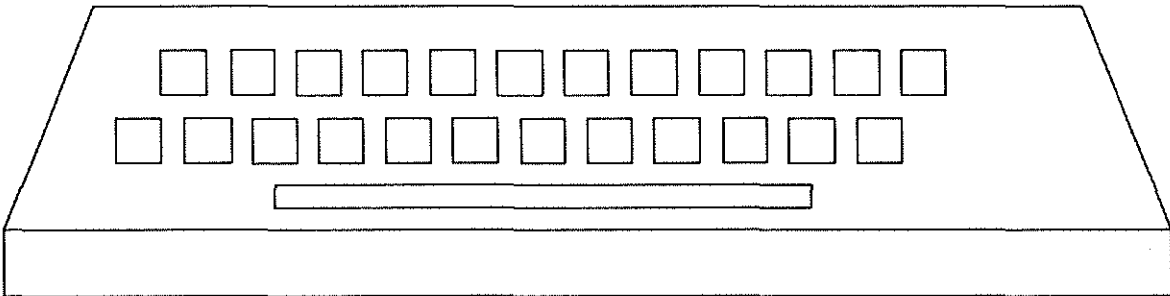

```

RTU 1 GA343A - WACKER OIL GA343A | 19:05:56
COUNTER INPT CHANNELS|- R E M O T E P O I N T S - Updated |11/30/90 19:04:15
CH TAG COUNTER NAME ACCUMULATED VALUE CONTROL --STARTED-- ALM
1 FQI401 Produced Water 0.00 Bbls 18:59 11/30
2 FQI470 Cond. Meter No. 1 0.00 Bbls 18:59 11/30
3 FQI471 Cond. Meter No. 2 0.00 Bbls 18:59 11/30
4 C4 Spare Counter 0.00 Bbls 18:59 11/30
5 FQI200 Test Sep. Cond. 0.00 Bbls 18:59 11/30
6 FQI201 Test Sep Water 0.00 Bbls 18:59 11/30
7 C7 Channel C7 0.00 Units 18:59 11/30
8 C8 Channel C8 0.00 Units 18:59 11/30

```

```

[S]tat [O]ut [A]log [M]eter [C]ntrs [F]rq [T]imer [Q]total [V]alue --+ ESC

```

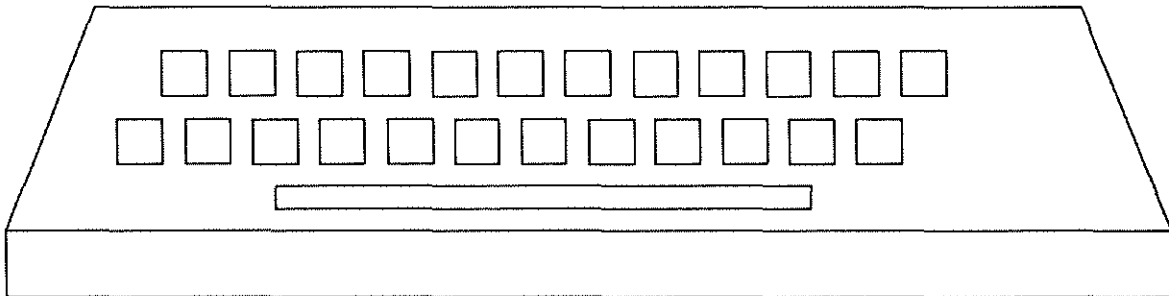

```

RTU 1 GA343A - WACKER OIL GA343A | 19:06:48
FREQ INPUT CHANNELS | - R E M O T E P O I N T S - Updated |11/30/90 19:04:15
CH NAME CURRENT VALUE CTRL UPDATE ALM
1 F1 Sales Rate #1 0.00 Cps
2 F2 Sales Rate #2 0.00 Cps
3 F3 Oil Sales Rate 0.00 Cps
4 F4 Water Rate 0.00 Cps

```

[S]tat [O]ut [A]log [M]eter [C]ntrs [F]rq [T]imer [Q]total [V]alue -+ ESC

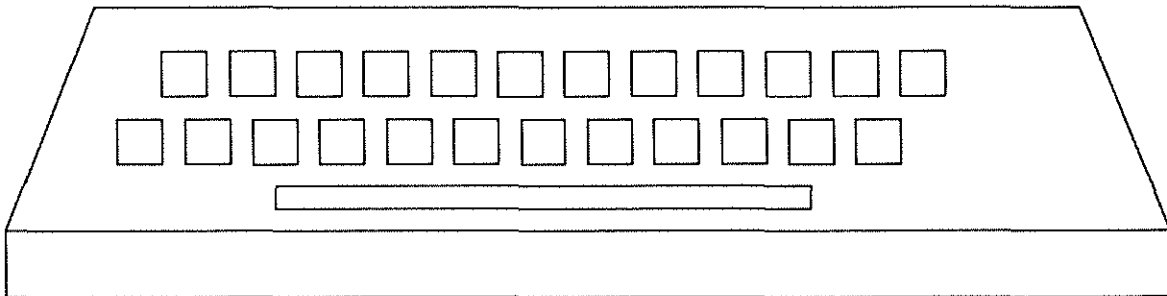

```

RTU 1  GA343A      - WACKER OIL GA343A                               | 19:08:02
TOTALIZER CHANNELS  |- R E M O T E  P O I N T S - Updated |11/30/90 19:04:15
CH  TAG      TOTALIZER NAME      TOTAL      CURRENT  --STARTED--  ALM
1   Q1      Sales Gas Meter #1     0.00 MMCF  0.00     18:59 11/30
2   Q2      Sales Gas Meter #2     0.00 MMCF  0.00     18:59 11/30
3   Q3      Test Sep. Meter           0.00 MMCF  0.00     18:59 11/30
4   Q4      Channel Q4              0.00 ---   0.00     18:59 11/30

```

[S]tat [O]ut [A]log [M]eter [C]ntrs [F]rq [T]imer [Q]total [V]alue -+ ESC

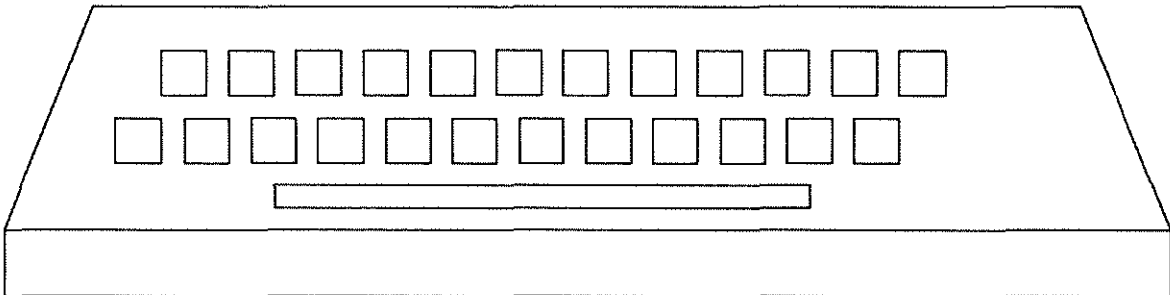

```

RTU 1 GA343A - WACKER OIL GA343A | 19:07:32
TIMER CHANNELS | - R E M O T E P O I N T S - Updated | 11/30/90 19:04:15
CH TAG TIMER NAME ALARM TIME TIME LEFT ACTIVE INP OUT ALM
1 T1 SSV Shutdown Pulse 00:00:00 00:00:00 No Off
2 T2 SCSSV Shutdown Pulse 00:00:00 00:00:00 No Off
3 T3 SCSSV Delay Timer 00:00:00 00:00:00 No
4 T4 Hurriane Evac Timer 00:00:00 00:00:00 No
5 T5 Channel T5 00:00:00 00:00:00 No
6 T6 Channel T6 00:00:00 00:00:00 No
7 T7 Channel T7 00:00:00 00:00:00 No
8 T8 Channel T8 00:00:00 00:00:00 No

```

[S]tat [O]ut [A]log [M]eter [C]ntrs [F]rq [T]imer [Q]total [V]alue -+ ESC

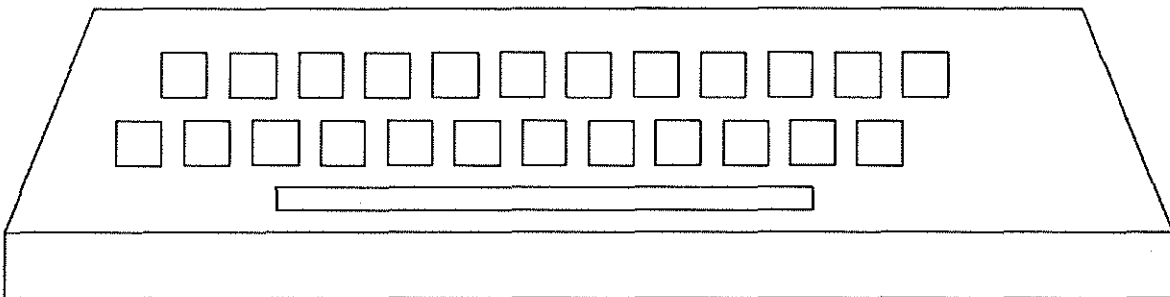

WACKER GA343A DAILY PRODUCTION REPORT
REPORT PRINTED ON 11/30/90

PREVIOUS DAY PRODUCTION

Sales Meter Number 1	0.00 MMCF
Sales Meter Number 2	0.00 MMCF
Sales Meter Total	0.00 MMCF
Pipeline Pressure	0.00 Psig

Data was transmitted from GA343 at 19:04:15 11/30/90

Hit any key to continue..

